



ULTRACARE

At the Cutting Edge of Industry

DR

BAND SAWING MACHINES

(30" & 36")

INSTRUCTION MANUAL No.823

FACSIMILE OF ORIGINAL WADKIN OPERATING & MAINTENANCE MANUAL

Wadkin

BAND SAWING MACHINES, TYPE D. R. WITH 30" and 36" WHEELS.

PRINCIPAL DIMENSIONS AND CAPACITIES :-

	English	Metric	English	Metric
Diameter of wheels.....	30"	762 mm	36"	914 mm
Width of wheels.....	1 $\frac{3}{4}$ "	44 mm	2"	51 mm
Maximum width of saw which can be used.....	1 $\frac{1}{2}$ "	38 mm	1 $\frac{3}{4}$ "	44 mm
Maximum length of saw.....	17'0"	5182 mm	20'0"	6096 mm
Minimum length of saw.....	16'0"	4877 mm	19'0"	5791 mm
Depth of cut under saw guide.....	14"	356 mm	18 $\frac{1}{2}$ "	470 mm
Maximum width of material accommodated on the left of the saw.....	28"	711 mm	34"	864 mm
Size of table.....	2'8" x 2'10"	813 mm x 864 mm	3'0" x 3'2"	914 mm x 965 mm
Table cants 45 ^o to right, 5 ^o to left.				
Height of table from floor level....	2'11 $\frac{1}{2}$ "	902 mm	3'4"	1016 mm
Horse power of motor.....	3	3	5	5
Speed of motor for built in motor drive.....	750 r. p. m.	750 r. p. m.	750 r. p. m.	750 r. p. m.
Overall height of machine.....	7'6"	2286 mm	8'6 $\frac{1}{2}$ "	2603 mm
Floor space for built in motor drive.....	4'8" x 2'10"	1422 mm x 864 mm	5'6" x 3'2"	1676 mm x 965 mm
Net weight in cwts.....	18 $\frac{1}{2}$ (2072lbs.)	941 (kilos)	21 $\frac{3}{4}$ (2436lbs.)	1005 (kilos)

DETAILS INCLUDED WITH THE MACHINE :-

Anti-friction guide above table
Hardwood guide below table
Hinged guards for saw pulleys

One set of spanners.
Lubricating pump and tin of lubricant
Motor, control gear and brake.

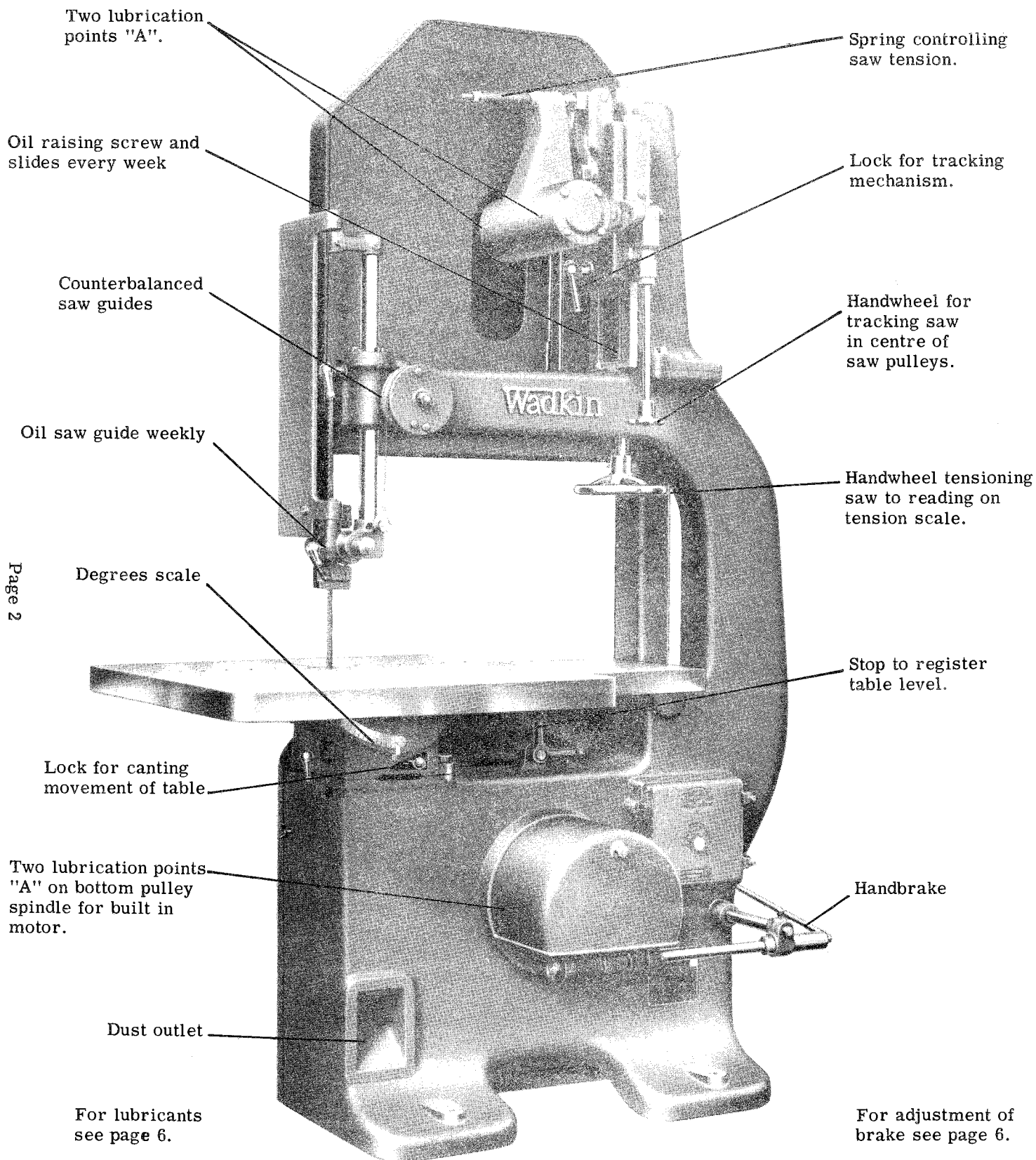

Two lubrication points "A".

Spring controlling saw tension.

Oil raising screw and slides every week

Lock for tracking mechanism.

Counterbalanced saw guides

Handwheel for tracking saw in centre of saw pulleys.

Oil saw guide weekly

Handwheel tensioning saw to reading on tension scale.

Degrees scale

Stop to register table level.

Lock for canting movement of table

Handbrake

Two lubrication points "A" on bottom pulley spindle for built in motor.

Dust outlet

For lubricants see page 6.

For adjustment of brake see page 6.

Page 2

Fig. 1

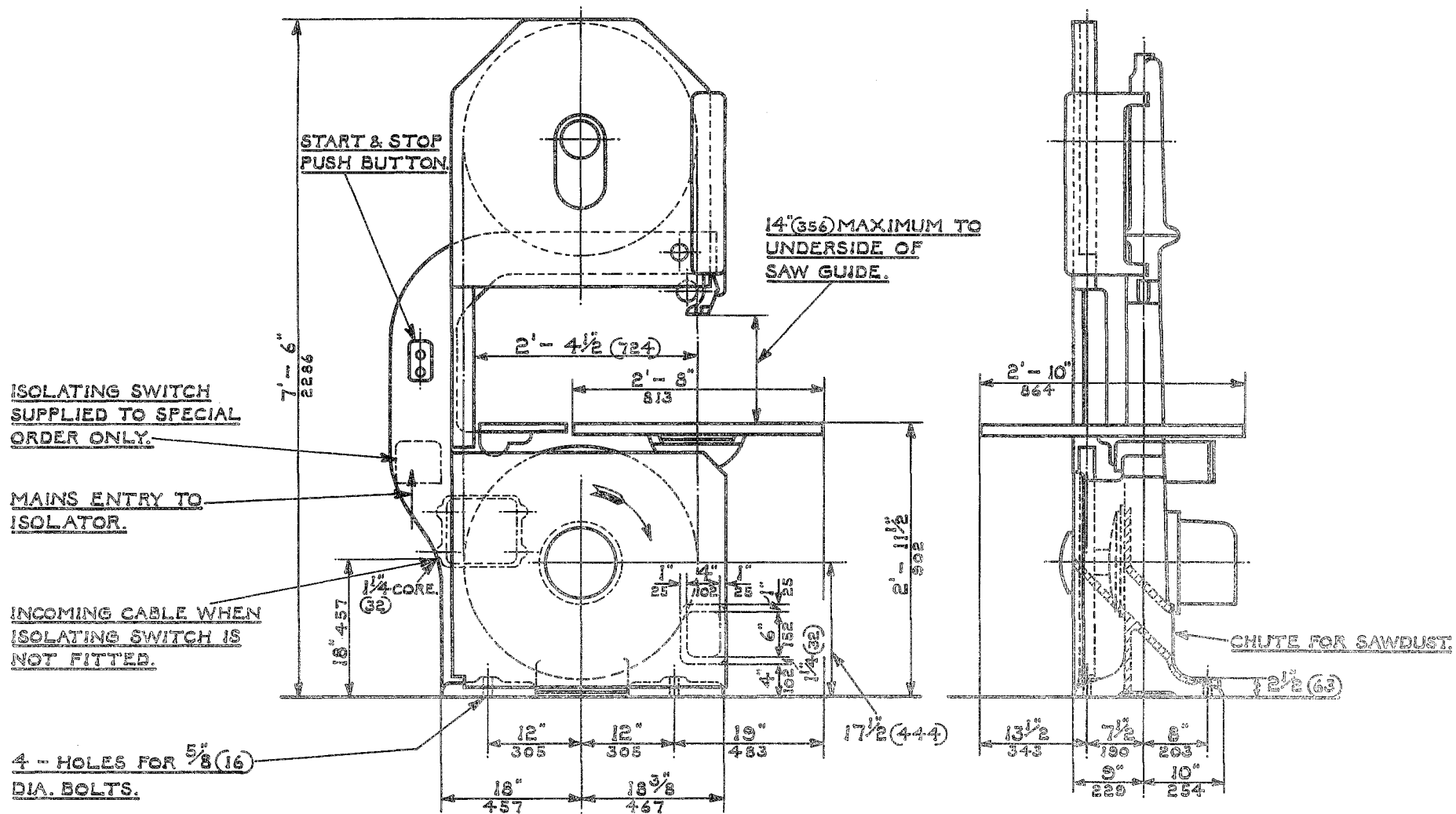

Fig. 2

HIGH SPEED BANDSAW. TYPE 30° DRA.

WITH BUILT IN MOTOR.

DIMENSIONS IN FEET, INCHES & MILLIMETRES.

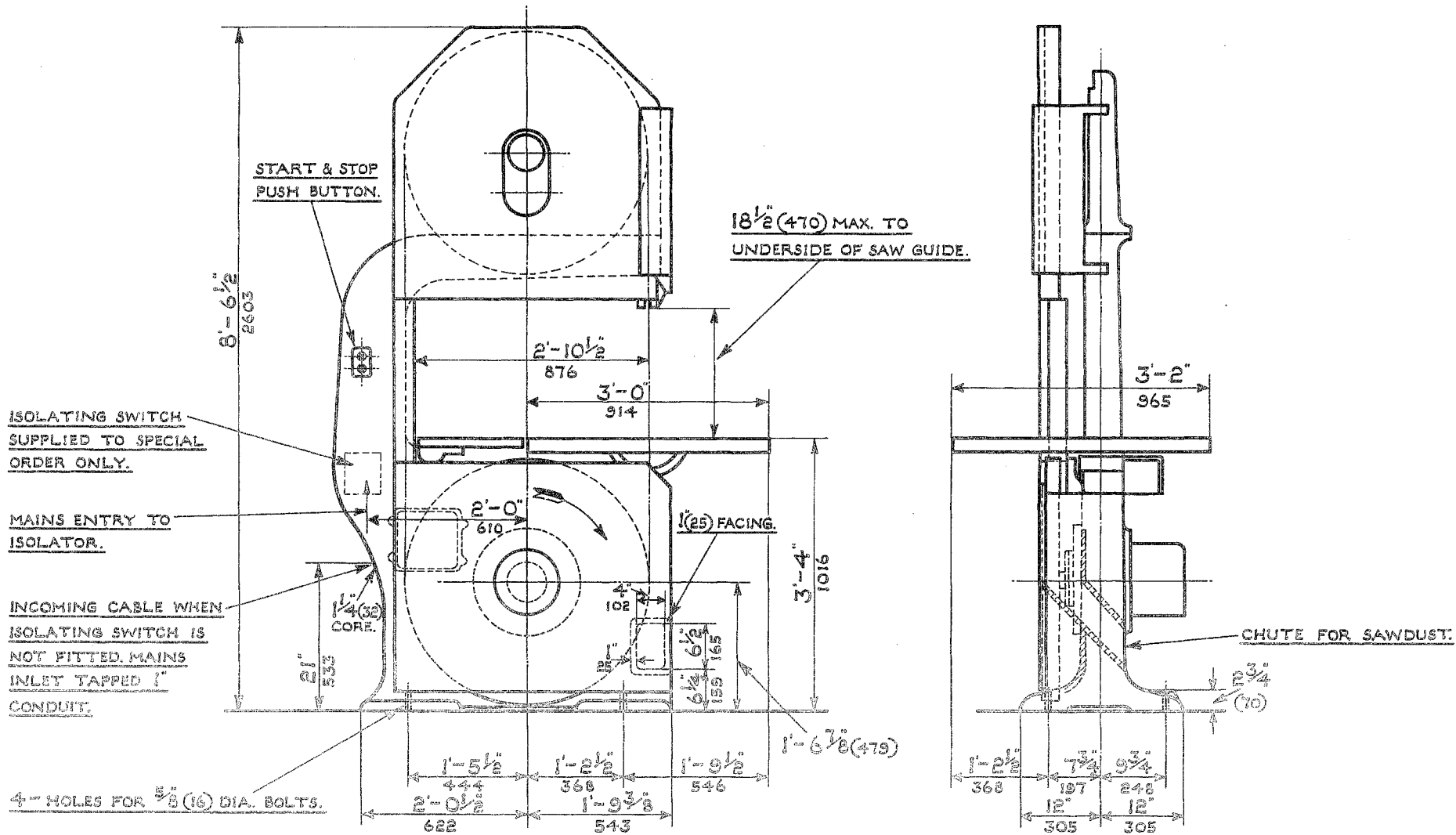

Fig. 3

HIGH SPEED BANDSAW, TYPE 36" DRA.

WITH BUILT IN MOTOR.

DIMENSIONS IN FEET, INCHES & MILLIMETRES.

INSTALLATION

The machine is despatched from the Works with all bright surfaces greased to prevent rusting. This protective covering must be removed by applying a cloth damped in turpentine or paraffin.

FOUNDATION.

Foundation bolts are not supplied with the machine unless specially ordered. If the mill floor consists of 4" (102 mm) to 6" (152 mm) solid concrete no special foundation is required.

"Rag" type holding down bolts may be used. Make 6" (152 mm) to 8" (203 mm) square holes in the concrete and place the machine in position. After carefully levelling grout in with liquid cement. It is advisable to re-level the machine again after the cement has set when the bolts should be tightened in order to prevent distortion of the main frame.

WIRING.

For detailed wiring instructions see wiring diagram on page 18.

DUST EXTRACTION.

The 30" machine has a built in chute with a 4" (102 mm) x 6" (152 mm) rectangular exhaust outlet. The 36" machine has a built in chute with a 4" (102 mm) x 6½" (165 mm) rectangular exhaust outlet.

BALL BEARING LIST

Makers Number	Size			Number Per Machine	Where used on Machine
	Bore	O/D	Width		
SKF. RM12	1½"	3¾"	15/16"	2	Top saw pulley) For 30" and
SKF. RM13	1. 5/8"	4"	15/16"	1	Front end of motor) 36" Type DRA
SKF. RL11	1. 3/8"	3"	11/16"	1	Rear end of motor) machines
SKF. RLS. 9	1. 1/8"	2½"	5/8"	1	Saw guide) direct motor
) driven.
SKF. RM12	1½"	3¾"	15/16"	3	2-Top saw pulley) For 30" and
					1-Bottom saw) 36" Type DRV
					pulley end) machines,
SKF. RM13	1. 5/8"	4"	15/16"	1	Rear end bottom) drive by vee
					saw pulley) or flat belt.
SKF. RLS9	1. 1/8"	2½"	5/8"	1	Saw guide)

NOTE: Spare bearings for the motor driving the D. R. V. type of machine will vary according to the type of motor in use. When ordering replacement motor bearings please state type of motor.

LUBRICATION

"A" - 4 POINTS (Shown on Fig. 1). Every 3 to 6 months give 4 to 6 depressions of the grease gun using Wadkin Ball Bearing Grease Grade L. 6.

For lubrication of saw guide use Wadkin Machine Oil Grade L. 4, but for details see instruction plate on inside of saw guard.

The raising screw and slides to top saw wheel should be oiled weekly using Wadkin Machine Oil Grade L. 4. The machine should be cleaned down weekly.

WADKIN RANGE OF OIL AND GREASE WITH EQUIVALENTS.

Wadkin Grade	Equivalent Lubricants		
	Shell Mex and B. P. Ltd.	Vacuum Oil Co. Ltd.	Caltex Lubricants
Oil Grade L. 4	Shell Vitrea Oil 33	"Vactra" Oil (Heavy Medium)	Caltex Aleph Oil
Ball Bearing Grease Grade L. 6.	Shell Nerita Grease 3	Gargoyle Grease BRB3	Regal Starfak No. 2 Grease

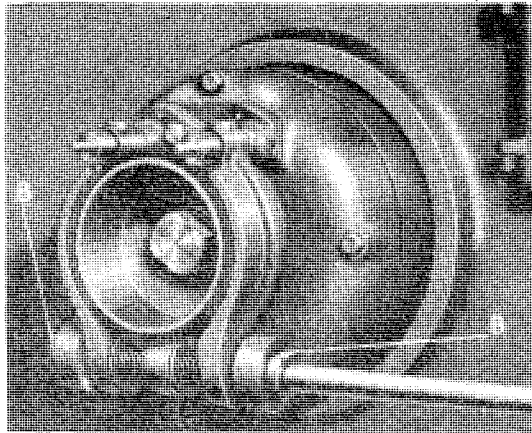

Fig. 4 BRAKE ADJUSTMENT

The brake is carefully adjusted before leaving our Works. If wear takes place in the brake linings after a period of running, the nuts 'B' must be screwed sufficient only to make the brake effective when controlled

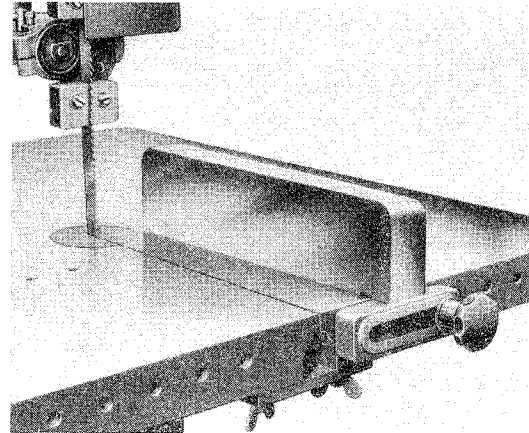

Fig. 5 PLAIN FENCE

This type of fence will work quite efficiently on either side of the saw.

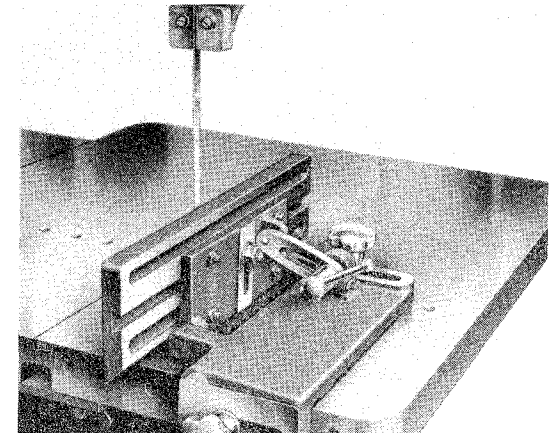

Fig. 6 CANTING FENCE

The canting fence is supplied to work on either the left or right side of the saw. Please specify which hand of fence is desired.

FITTING BANDSAW BLADES

SAW GUIDES - Fig. 7.

When placing a saw on the machine the top and bottom guides must be moved well back and the saw tracked or adjusted to run in the centre of the saw wheels. Afterwards bring both guides forward until the discs barely touch the saw when not working. The side blocks on the guides should support the saw on the sides, but not allowed to nip the blade. Keep the side blocks up to the gullets of the teeth only leaving the teeth clear. When using saws of the same width they will usually run successfully without altering the adjustment, but when wider ones are used the guides must be moved back and the saw re-tracked. To obtain first class sawing, the guides must be dead in line and fixed immediately above the work.

TENSIONING - Fig. 8.

Incorrect tension or tightness of the blade over the saw will end in saw breakage. The scale and pointer are set before despatch, but should they be displaced in transit it is necessary to re-set them before use. In placing a saw on the pulleys it should be sufficiently tight until it can be pulled out $\frac{1}{4}$ " from its true line at a central point, between the two pulleys. When this is done, move the pointer until the scale coincides with the width of the saw. For a $\frac{1}{2}$ " blade the pointer should read $\frac{1}{2}$ ". If the machine is left standing for a period, e.g. overnight, the tension should be reduced, and the blade re-tensioned before putting the machine into operation again.

IMPORTANT.

After the pointer is fixed in this manner it will read correctly for any width of blade without further alteration, even if the length of saw varies for any given width. For a $\frac{3}{4}$ " blade the pointer should read $\frac{3}{4}$ ", etc.

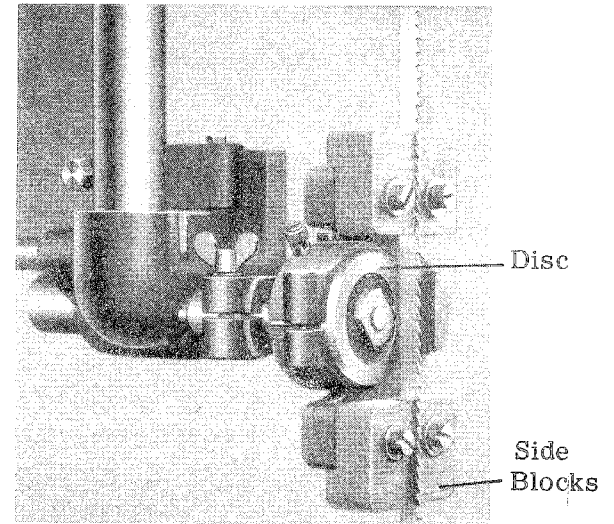
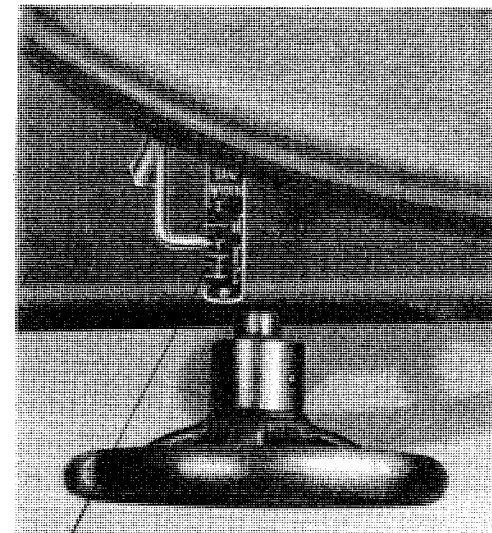

Fig. 7



Scale
and
Pointer

Fig. 8

FITTING BANDSAW BLADES (Continued)

TRACKING - Fig. 9.

Every saw has slightly different running characteristics on a band saw machine due to the condition of the steel ribbon it is made from, the brazed joint and the tension in the blade ribbon. This is compensated by using a crowned (or slightly curved) rubber on the wheels and providing the top wheel with a slight tilting movement. We call this tracking and by slackening the lock handle and adjusting the tracking hand-wheel, it is possible to adjust the tilt of the top wheel, so that the saw runs steadily in the centre of the wheel. This is important because the blade then passes in a straight line between the top and bottom wheel, and does not snake. When the latter occurs the back of the saw keeps hitting the guide plate and woodwork and damaged guides result. Do not forget to re-tighten the tracking lock bolt after adjusting.

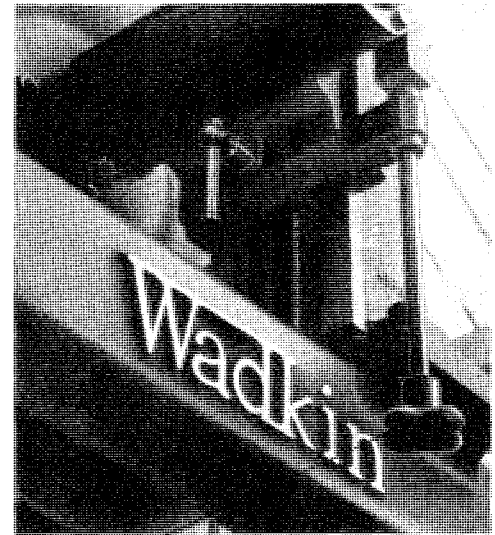

Small hand wheel
for tracking saw

Fig. 9

SAW PULLEYS

A brush as shown in Fig. 10 is provided on the bottom pulley to remove sawdust, whilst the rubber on the top pulley should be cleaned daily to prevent accumulation of sawdust which would cause the blades to run out of true line.

The saw pulleys must be kept in accurate balance to avoid vibration. It is essential that the rubbers on the faces of the pulleys are kept at an even thickness by truing up occasionally or if they are badly worn should be replaced by new ones. If the machine is used with badly worn pulleys the saw will vibrate, resulting in bad sawing and broken saws.

We have a service arrangement which we recommend whereby newly rubbered pulleys can be supplied against the return of the existing pulleys, an appropriate charge being made to cover re-rubbering only. Where it is not practical for the customer to use our exchange service of vulcanised wheels it is possible for the customer to carry out his own re-rubbering, which, whilst not so good as the vulcanised process, is satisfactory if the instructions below are carefully followed. Rubber bands and fixing solution can be supplied to order.

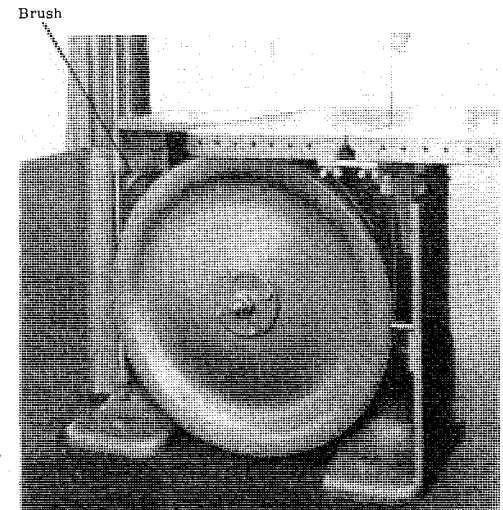

Fig. 10

REMOVAL OF SAW PULLEYS.

The top and bottom pulleys are identical, and when taking them from the machine for re-rubbering the entire wheel comprising plate and hub should be removed. To do this remove the spindle nut and withdraw the wheel complete. It should be noted that for both pulleys this locknut has a left hand thread.

FIXING INSTRUCTIONS FOR THE APPLICATION OF RUBBER BANDS TO BAND SAW PULLEYS.

The Croid Glue No. 9 supplied is ready for use and should be applied cold.

In cold weather and if the glue is solidified warm up to 80° Fahrenheit to give fluidity and to assist spreading.

Thoroughly scrape and clean the face of the wheel free from old abrasive. This is very important.

Stretch the rubber band over the wheel.

To assist with the application of the glue it will be found more convenient to place between the wheel rim and the rubber a piece of wood approximately $1\frac{1}{4}$ " diameter. Apply the glue across the face of the wheel and turn the wood round the rim thereby exposing a section of the rim to be glued. Proceed until the whole of the wheel has been covered taking care to glue the whole face in order to obtain adhesion over the whole width to prevent the edges of the band lifting.

Tightly apply a piece of tape of the same width as the wheel around the circumference, thereby giving as much pressure as possible to the rubber band. Leave at least 24 hours before use.

Finally true up the rubber and put a slight crown on the face. This is done by revolving the wheel and holding against it a wood block covered with emery cloth, preferably when mounted on the machine. Check wheel for balance before use.

FOR TROPICAL COUNTRIES a Croid Glue No. 10 is supplied with a hardening powder which must be added in the proportion of one part of hardener to 56 parts by weight of glue and thoroughly mixed. The remainder of the procedure for cleaning and fixing is the same as in the instructions above.

MAINTENANCE OF BAND SAW BLADES

A properly sharpened band saw will give clean, accurate cutting and this is achieved by proper setting and sharpening of the teeth. Always set before sharpening.

SETTING.

In order to cut satisfactorily band saw teeth must be set. This consists in bending the teeth alternately out of the line of the blade. This presents alternate pairs of teeth, wider than the thickness of the ribbon and prevents the ribbon rubbing in the wood being cut and getting hot.

There are two usual ways of setting bandsaw teeth depending generally upon the amount of work to be done.

(1) The use of a hand setting tool of the plier type.

(2) Machine setting. The standard filing machine described on page 15 can be changed over from filing to setting action, but many firms prefer to install a separate inexpensive setting machine as described on page 16. The difference between the machines (Figures 15 and 16) is one of capacity of saw width and pitch, and the advantage of these machines is that the strikers which push the teeth over, are arranged on opposite sides of the blade, and strike adjacent teeth simultaneously. In this way the shock of the two strikers cancel each other out, and does not damage the body of the band ribbon.

Where hand setting is employed it cannot be ensured that all the teeth are cutting and in order to overcome this the teeth should be stoned occasionally. An ordinary fine grit stone is used and the ball bearing guide should temporarily be brought forward until the thrust disc is in contact with the back of the blade. The blade should then be run and the stone carefully applied to the teeth each side of the blade. When the saw is subsequently sharpened it will be noted that each tooth has not been marked with the stone, and such teeth should only

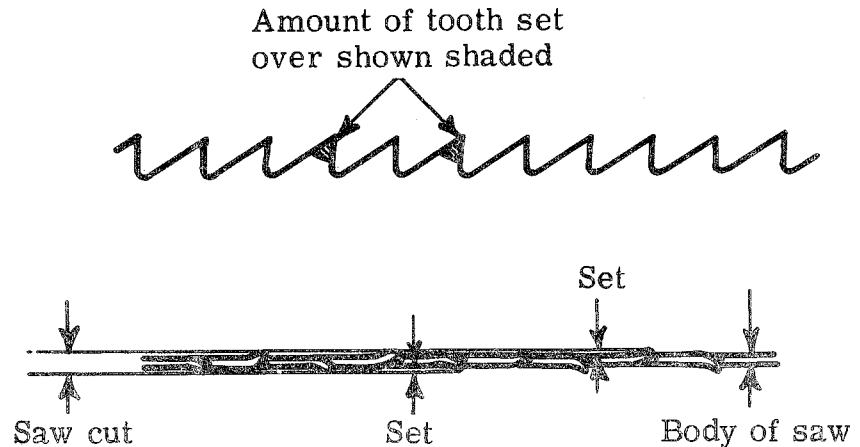

SETTING (Continued)

be filed very slightly. The remainder of the teeth which have actually been stoned should be filed in the used manner until the flat caused by the stone disappears. Bandsaws may be stoned approximately once to every six sharpenings.

The points of the teeth are set by using a handsetting tool of the plier type. The points only of the teeth must be set and as a general guide the set on each side is .010". Set is applied in opposite directions for each alternate tooth.

SHARPENING.

This is normally done by using a triangular section file. Again the operation can be done by hand or machine.

HAND FILING.

It is essential to employ an efficient and quick acting vice and round cornered triangular files, both as illustrated on page 14. The face of each tooth should be filed across and with the same stroke

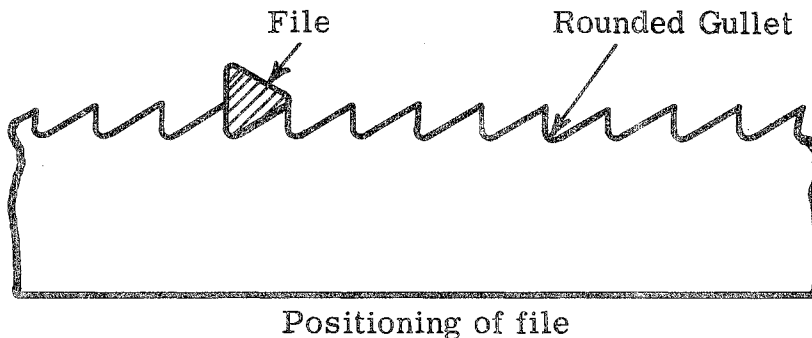
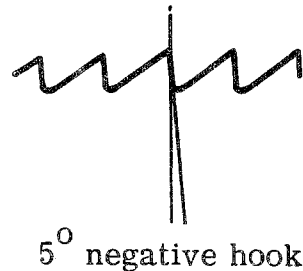
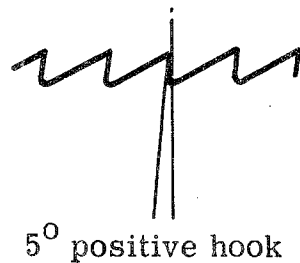

the back of the following tooth should be filed at the same time. One stroke of the file should be sufficient to sharpen each tooth, and this stroke should be as light as possible in order to avoid producing a burr. The shape of the gullet is automatically maintained at 60° by the file, while the angle of the hook on the tooth is dependable on the positioning of the file. For general work approximately 5° of positive hook should be given. A greater or smaller hook should be applied for softer or harder woods respectively. In the case of particularly hard woods a negative rake may be necessary, while a wider tooth pitch than standard may be required for sawing timbers of an abrasive nature, and those containing gum.

SHARPENING (Continued)

Always sharpen square across the face of each tooth and NOT on the bevel, otherwise the saw will vibrate violently, which shatters the steel, and cracks appear causing saw breakage.

Use a file with rounded corners and of triangular section. It is important to keep the gullet of each tooth rounded otherwise cracks will soon appear. Saws must be sharpened at regular intervals and should never be forced to cut with teeth which have become blunt.

N. B.

When reconditioning bandsaw blades it is necessary to set the teeth first before sharpening.

This ensures that the face of the tooth is square. If the sharpening were carried out first, the subsequent setting would result in an angular tooth shape being obtained.

MACHINE FILING.

A picture of the automatic machine for filing blades is given on page 15. Further details of this machine will be forwarded on request.

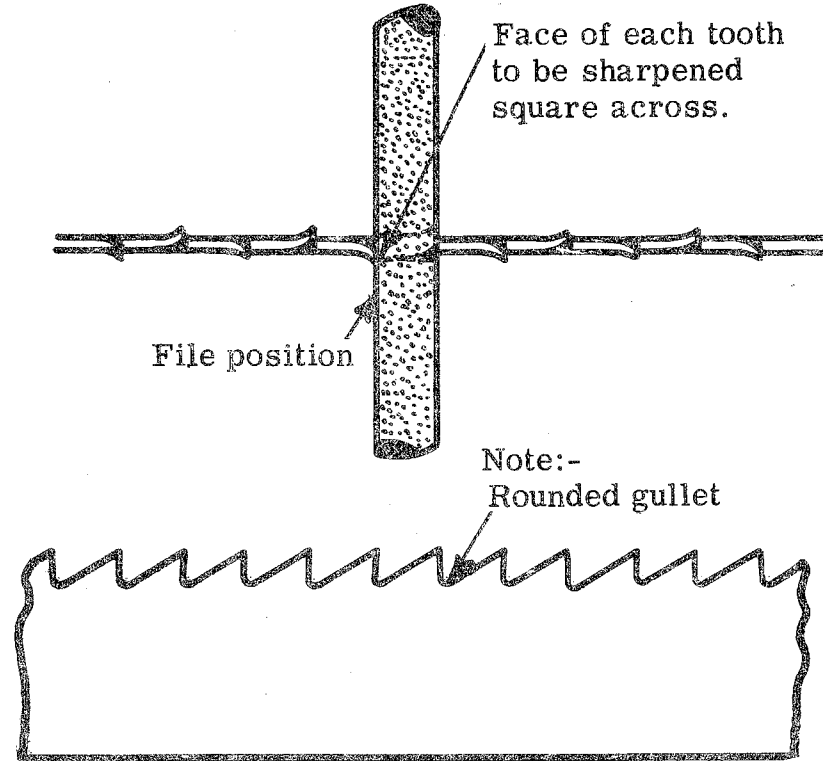

GENERAL CAUSES OF SAW TROUBLE, CRACKING AND BREAKAGE

1. Crystallisation of the ribbon, produced by the back of the saw rubbing against the metal disc of the saw guide. The disc should revolve only by contact with the back edge of the saw when actually cutting.
2. Using a blade that is too wide for the radii being cut. In attempting to cut small curves with a saw too wide the blade tends to twist against the guides causing friction and over-heating which destroys the temper in the steel.

SMALLEST RADII WHICH MAY BE SAWN WITH GIVEN WIDTH OF BLADE

Width of Blade	1/8"	3/16"	1/4"	3/8"	1/2"	5/8"	3/4"	1"
Minimum Radius	1/8"	5/16"	5/8"	1.7/16"	2 1/2"	3 3/4"	5.7/16"	7 1/2"

NOTE: ALWAYS USE WIDEST BLADE COMPATIBLE WITH THIS CHART.

3. Not enough set.
4. Sharpening with a sharp cornered file.
5. Bad brazing due to dirty joints or badly prepared laps or incorrect positioning of the laps, causing a bump on the back of the blade at the joint.

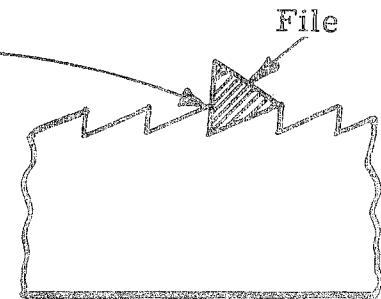

(For details of good brazing of a fracture see page 15).

TAPER TRIANGULAR FILES FOR HAND USE

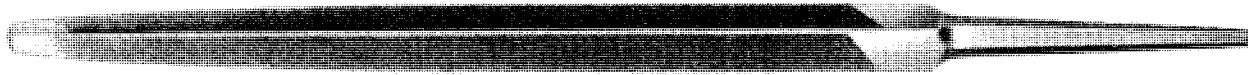

Fig. 11

Length 6" 8" 10"

The edges of both machine and hand files have rounded corners to produce the round gullet which prevents saw cracks.

BAND SAW FILING VICE

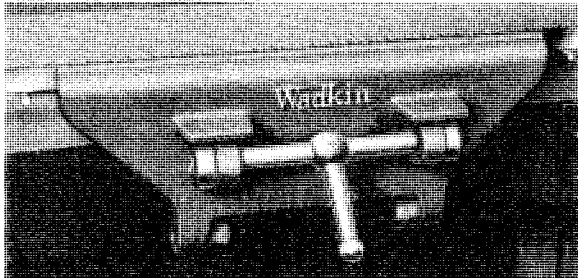

Fig. 12

A specially designed vice for holding band or fret saws also hand saws. Jaws are 17" long and will take saws up to 2½" wide. Jaws open instantaneously by lever handle.

Spare bandsaw blades for wood cutting on the 30" and 36" D. R. Bandsaws are available from stock. (Maximum and minimum lengths given on page 1). Where it is preferred bandsaw blading in strip form can be supplied for customers to make up their own blades. This bandsaw strip is offered either toothed only, or toothed, sharpened and set.

SPECIAL MATERIALS.

In addition to woodcutting we can supply bandsaw blades suitable for plastics, bonded wood, non-ferrous metals, meat, etc., providing that the correct machine speeds are available. If any special material is to be cut, a sample should be sent to Wadkin Ltd. for test purposes so that the correct type of blade may be recommended. We are able to offer special speed bandsaws for specific purposes and full details will be sent on request.

WADKIN BAND SAW FILER AND SETTER, TYPE H. D.

This machine is fully automatic and ensures that each tooth is sharpened and set to the correct shape and depth.

Any length of saw can be dealt with, and the maximum width is $2\frac{1}{4}$ " with teeth up to $\frac{5}{8}$ " pitch for filing and $1\frac{1}{2}$ " wide for setting.

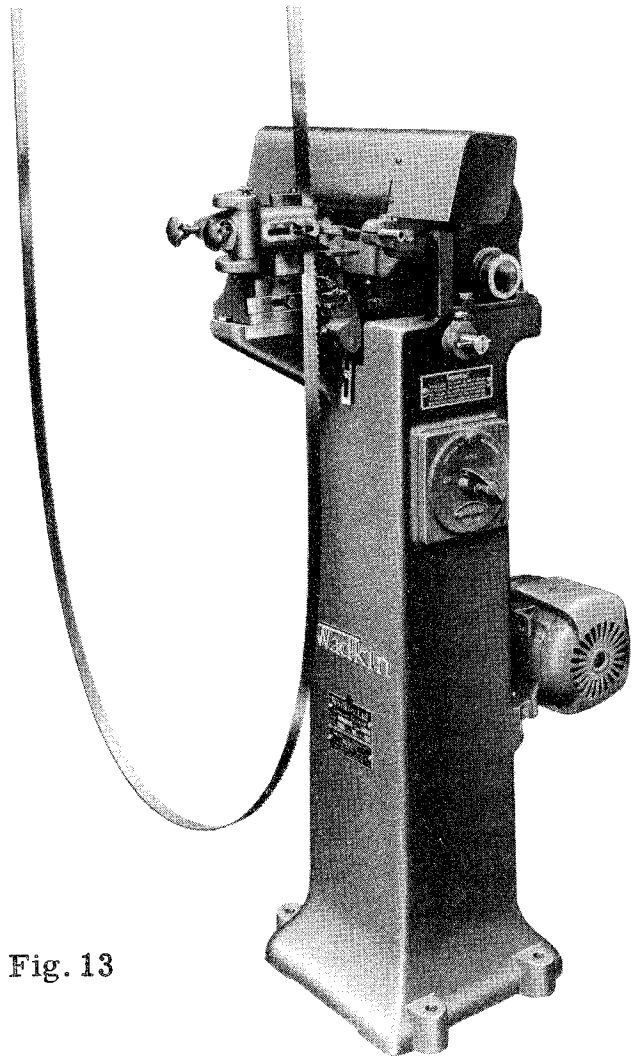

Fig. 13

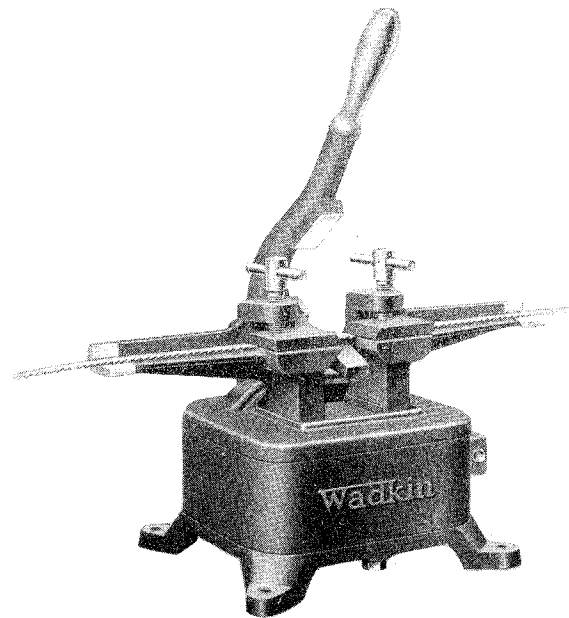

Fig. 14

WADKIN ELECTRIC BAND SAW BRAZER, TYPE H. E.

This machine is suitable for brazing band-saws from $\frac{1}{4}$ " to 1" wide, and is very useful for the efficient brazing of blades which have become broken. The two ends of the saw are firmly held by the clamps, and controlled heat applied electrically. A small quantity of solder and brazing compound are supplied with the machine. The actual brazing takes from 25 to 45 seconds according to width of blade. Before brazing the ends of the saw blade must be carefully bevelled. A separate instruction chart is issued with the brazer.

When the amount of work does not justify the installation of the equipment shown on page 15 we can offer a prompt and efficient repair and reconditioning service. Any blades sent to us for reconditioning should be covered by an official order.

WADKIN BAND SAW SETTING MACHINES

For manual setting the following equipment is recommended.

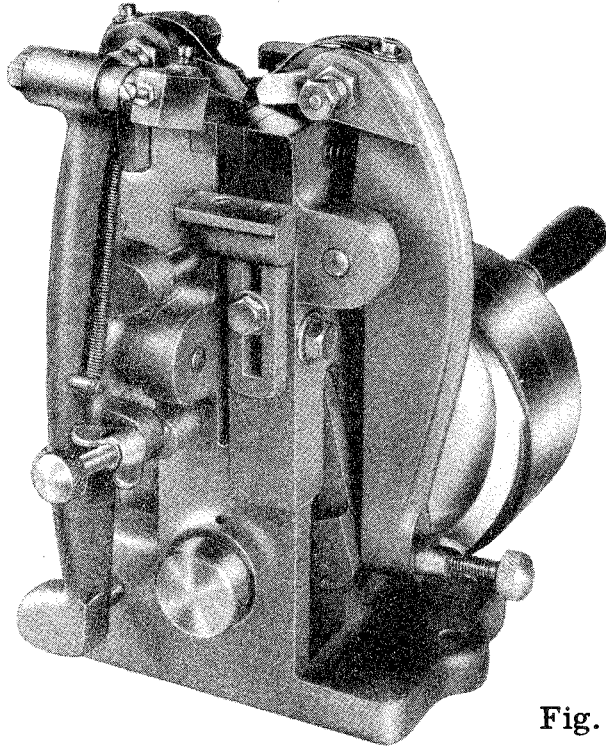

Fig. 15

FOR BAND SAW BLADES UP TO 3" WIDE
7/8" PITCH TYPE B/LS

This is a heavy duty machine which sets two teeth at each revolution, giving a rate of approximately 200 teeth a minute on the general run of work.

The machine may be used either by hand or power, the handwheel being in the form of a pulley to take a belt from motor or lineshaft.

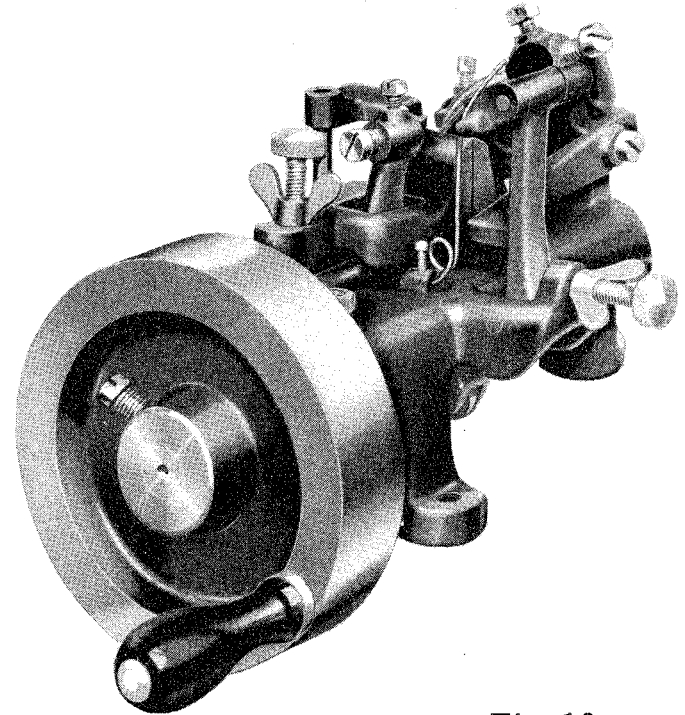

Fig. 16

FOR NARROW BAND SAWS UP TO 1 1/4" WIDE
1/2" PITCH TYPE B/SS

All adjustments are quickly and easily made to this robust and thoroughly practical tool. It is usually operated by hand and setting is at the rate of two teeth per revolution of wheel. When preferred the machine may be power driven by flat belt on the pulley face of the handwheel.

ELECTRICAL INSTALLATION INSTRUCTIONS

The cabling between the motor and the control gear has been carried out by Wadkin Ltd., and it is only necessary to bring the line leads to the machine for it to be put into service. This should be done as follows :-

- (1) Fit triple pole isolating switch near the machine, unless this has been supplied to special order by Wadkin Ltd., when it will be fitted and connected up at the machine.
- (2) Connect the line lead to the appropriate terminals, see diagram. The cables should be taken to the machine in conduit and secured to the control gear by means of locknuts.
- (3) Connect solidly to earth.
- (4) Close isolating switch and press start button. If machine does not rotate in the right direction, interchange any two incoming line leads.

FAILURE TO START

- (1) Electric supply is not available at the machine.
- (2) Fuses have blown or have not been fitted.
- (3) Isolating switch has not been closed.
- (4) Lock-off or stop button has not been released.

STOPPAGE DURING OPERATION AND FAILURE TO RESTART

- (1) Fuses have blown.
- (2) Overloads have tripped. They will reset automatically after a short time, and the machine can be restarted in the usual manner.

ADJUSTMENT

For a finer overload setting, set the load indicator to a lower value, and vice-versa for a less fine setting.

GENERAL

Check the earth connection from time to time. Users are recommended to display in an appropriate position in the maintenance department Wadkin Electrical Maintenance Instruction Card, No. 356, which is issued gratis on application.

FOR PARTICULARS OF WADKIN PORTABLE ELECTRIC BLOWER FOR CLEANING M/C & ELECTRICAL GEAR SEE LEAFLET No. 687.

RETAIN THIS DIAGRAM FOR FUTURE REFERENCE.

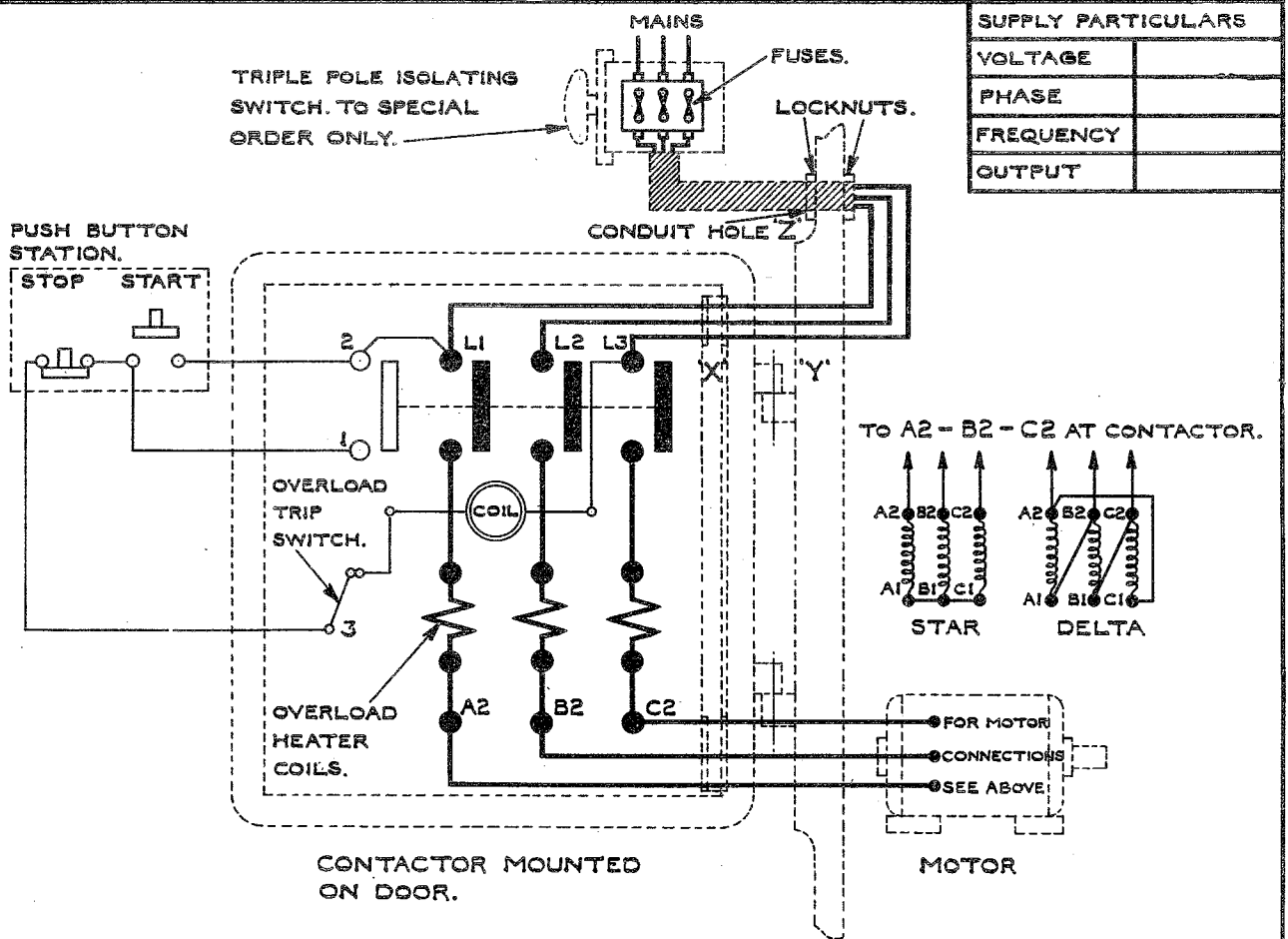

INSTALLATION INSTRUCTIONS.

FIT TRIPLE POLE ISOLATING SWITCH NEAR MACHINE UNLESS SUPPLIED BY WADKIN LTD. TO SPECIAL ORDER, SO THAT THE ELECTRICAL GEAR MAY READILY BE ISOLATED FOR INSPECTION PURPOSES. BRING LINE CABLES TO ISOLATING SWITCH AND TO L1 - L2 - L3 AT CONTACTOR THROUGH CONDUIT WHICH SHOULD BE SCREWED INTO THE MACHINE AND SECURED BY MEANS OF LOCKNUTS. A HOLE IS PROVIDED IN THE MACHINE FRAME AT 'Z' FOR THE CONDUIT CARRYING THE LINES TO THE CONTACTOR.

OPERATING INSTRUCTIONS.

TO START MOTOR, CLOSE ISOLATING SWITCH AND PRESS START BUTTON. TO STOP MOTOR PRESS STOP BUTTON. TO LOCK OFF MACHINE PRESS AND TURN STOP BUTTON. THIS MUST BE RELEASED BEFORE A START CAN BE MADE.

NOTE :-

CABLING SHOWN THUS  TO BE CARRIED OUT BY CUSTOMER UNLESS ISOLATING SWITCH HAS BEEN FITTED BY WADKIN LTD.

WADKIN LTD.
LEICESTER.

IMPORTANT.

SECURE LINE CABLES AT 'X' BY MEANS OF THE CLEAT PROVIDED. LEAVE SUFFICIENT SLACK IN LINES AT 'Y' TO ALLOW THE DOOR TO OPEN FREELY.

WHEN DUAL VOLTAGE MOTORS ARE EMPLOYED THE FOLLOWING CONNECTIONS SHOULD BE MADE 200/250 VOLT CIRCUITS CONNECT MOTOR IN 'DELTA', 340/440 VOLT CIRCUITS CONNECT MOTOR IN 'STAR', THE CONNECTIONS BEING MADE EITHER WITHIN THE CONTROL GEAR CAVITY OR AT THE MOTOR TERMINAL BLOCK.

ENSURE THAT THE MACHINE IS ADEQUATELY 'EARTHED' AND THAT THE DIRECTION OF ROTATION IS CORRECT BEFORE PUTTING INTO SERVICE. TO REVERSE ROTATION INTERCHANGE L1 & L2.

OVERLOAD.

SHOULD THE MOTOR STOP DUE TO OVERLOAD, WAIT FOR A SHORT TIME TO ALLOW THE HEATER COILS TO COOL AND THEN START IN THE USUAL MANNER.

EARTH MACHINE.

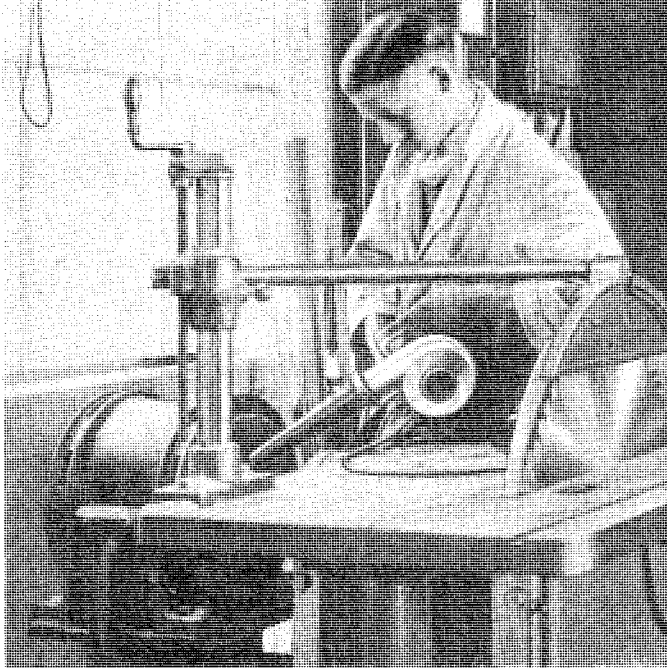

**DONT LEAVE ELECTRIC
MOTORS TO LOOK AFTER
THEMSELVES . . .**

**. . . blow away harmful dust,
chips and dirt with a
Wadkin Electric Blower**

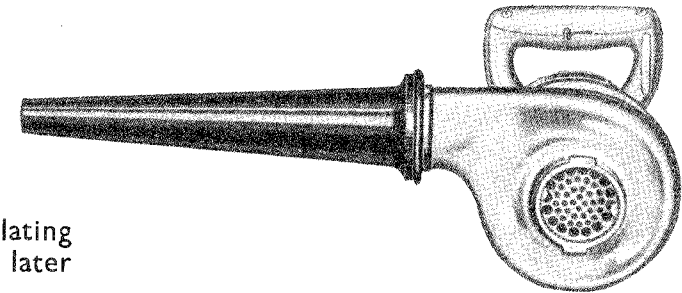

No motor can run at its maximum efficiency with its ventilating duct or control gear covered with dust and dirt. Sooner or later the resultant overheating will cause serious trouble.

Similarly, accumulations of chips and dust, in the mechanical parts of the machine can interfere with its efficiency. A few minutes a week for blowing down all Woodworking Machinery will be amply repaid in better and easier running, in increased life, and freedom from breakdown.

Blowers can be supplied for single phase A.C. or Direct Current for any voltage up to 250.

Please state voltage when ordering.

SPECIFICATION

Horse-power of motor	1/2rd
Net weight...	7 lbs.
Speed	11,400 r.p.m.
Velocity of air in feet per minute	14,800
Fully guaranteed for one year				

Wadkin

ULTRACARE LTD.
spares +44 (0)870 850 9114
tooling +44 (0)870 850 9113
service +44 (0)870 850 9112