



Chapter 3

Computer Hardware



Topics you will explore include:

- Computer Systems
 - Supercomputer
 - Mainframe
 - Personal
- Computer Platforms
- Hardware Components
 - System Unit
 - CPU
 - Primary Memory
 - Expansion Ports
 - Peripheral Devices
 - Secondary Storage Options
 - Magnetic
 - Solid State
 - Optical
 - Input Devices
 - Output Devices
- Networks
 - LAN
 - WAN
 - Internet

Computer technology has transformed our lives for over 50 years. First introduced to alleviate the tedious work of calculating long data tables for the military, we now find computers recording and processing every aspect of our daily activity. The modern computer is no longer just a numeric calculator; it is a multimedia device that displays images, sound, and video through operating systems and applications that give the user unprecedented control over information. Visionaries such as Alan Turing and Vannevar Bush articulated the direction for such computers, but it was the development of microelectronics that brought multimedia to our desktops. Powerful computing devices make multimedia applications possible. They capture and convert input from various analog sources, process and store the digital data, and output in ways that empower users to create, distribute, search, and share information as never before. Hardware powers the development and delivery of multimedia.

In this chapter you will explore the basic components of a computer system including the peripheral devices used for developing multimedia applications. Developers are concerned about the performance features of not only the processor, but also all input, storage, and output devices. After completing this chapter you should understand:

- Components of a computer system
- Types of computer systems
- Functions and components of the central processing unit (CPU)
- Functions of the system board and hardware interface
- Peripheral devices and performance criteria for:
 - Secondary storage
 - Input
 - Output
- Network fundamentals

3.1 Computer Systems

A **computer system** is an integrated set of hardware and software designed to process data and produce a meaningful result. Every computer performs the basic functions of *input, processing, storage, output, and transmission of data*. Instructions and data are entered, processed into results that are stored for later use, and output in a useful format. Computers are connected to a larger network system for transmission of data and information.

Computer hardware is organized according to these basic functions. The *system unit* focuses on processing, whereas a variety of *peripheral devices* facilitate input, output, storage, and communication.

Types of Computer Systems

Computers are often identified by their size and power. Common categories of computer systems include *supercomputers, mainframes, and microcomputers*. Size traditionally refers to the computer's physical mass, whereas power refers to the computer's speed and the complexity of calculations it can carry out. Originally, mainframe computers

were physically much larger than desktop microcomputers. Size is now less significant, because microelectronics can package very powerful systems in very small spaces.

Supercomputers are the most advanced, powerful, and expensive computers of the day. They are characterized as having the fastest processing speeds and performing the most complex calculations. Today those speeds can reach quadrillions of calculations per second; tomorrow they will be even faster. Supercomputers are unlocking many mysteries of our universe. They are widely used in scientific research, artificial intelligence, defense systems, and industrial design. More recently, they have been applied to multimedia development. For instance, in the film industry, supercomputers are used to carry out the rendering operations that transform digital animations into magical three-dimensional worlds.

Supercomputer speed and power can be achieved by uniting individual CPUs through a network of distributed computers. The Berkeley Open Infrastructure for Network Computing (BOINC) sponsors open source software for volunteer computing and grid computing to tackle complex research projects. In 2012, BOINC reported sharing over 400,000 computers that delivered 6.438 PetaFLOPS of computing power. See <http://boinc.berkeley.edu/>.

A **mainframe computer** is an advanced multiuser machine typically used to manage the databases, financial transactions, and communications of large organizations such as banks, hospitals, retail stores, insurance companies, and government offices. While these applications don't require the computational complexity of supercomputers, mainframes are still very powerful: they can process billions of instructions per second, support hundreds of users, and store terabytes (trillions of bytes) of data. Supercomputers and mainframes are very expensive and require a support staff to maintain daily operations. These computer systems are vital to the performance of many daily tasks but it was the personal computer that transformed the way most of us think and work.

A **personal computer (PC)** is a system that uses a microprocessor to provide computing to a single user. Personal computers have many different names and configurations including **microcomputer**, laptop, desktop, and tablet (Figure 3.1). The first personal computers were developed in 1975 by computing enthusiasts who wanted their own computer rather than share a large centralized mainframe. Their efforts were energized in 1971 when Intel introduced the microprocessor. A **microprocessor** is a single silicon chip that contains all the elements of a central processing unit (CPU). This miniature CPU was not as powerful as a mainframe, but it was much smaller and cheaper. It was perfect for a single user who wanted computing capability on the desktop.

Altair, the first microcomputer, appeared in 1975 and launched the microcomputer revolution. In 1977, Commodore Pet and Apple II followed. The IBM PC appeared in 1981. IBM used the Intel microprocessor to build office computers for word processing, spreadsheets, and databases. These applications focused on text-based data to improve business productivity.

On January 24, 1984, Apple introduced a different type of microcomputer, which relied on images and sound to interact with the user. Steve Jobs and Stephen Wozniak captured the visions of Bush, Engelbart, and Kay when they delivered the first commercial multimedia computer. The Macintosh used an operating system with a graphical



Figure 3.1 Common microcomputer systems.

interface that resembled a standard desktop complete with folders and a trash can. It relied on a mouse to manipulate data and programs. It included sound capabilities and dramatically introduced itself at the January 1984 debut. From that day on, advances in hardware technology supported the development of multimedia computing. Today's microcomputer is in every way a multimedia machine.

3.2 Computer Platforms

Computers have fundamental differences based on the hardware components, such as processors, and the operating systems that they use. An operating system is the software that manages the computer's resources and executes application programs. The combination of hardware and operating system is often called the **computer platform**.

Microcomputer Platforms

The two most common microcomputer platforms are Macintosh and Windows-based PCs. The Macintosh platform utilizes hardware developed by Apple. Apple defines the hardware specifications and develops the operating system to control the hardware. Apple currently manufactures multimedia computers in several configurations: MacBook (end user laptop), iMac (end user desktop), and Mac Pro (developer system). The most popular personal computer today is a Windows/PC platform. These microcomputers utilize the Windows operating system developed by Microsoft. Many companies, such as Dell, Gateway, HP, and Sony, build Windows/PC computers. You might even build one yourself, as the hardware components are readily available from a variety of manufacturers.

Understanding the distinctions between computer platforms is important for multimedia development. Developers who plan to reach a wide market are concerned about **cross-platform compatibility**, the ability of an application to run on different hardware and operating systems. For example, images that are saved in a color palette and file format optimized for the Windows/PC platform may appear distorted on a Macintosh computer. Font technologies and typeface families also vary between the two platforms. Advances are underway to standardize digital media formats so they can be utilized on both platforms. Adobe Acrobat, now in widespread use, provides one successful cross-platform format for text and images. The World Wide Web is a major catalyst for defining data formats so that they can be viewed on any computer through network connections and a browser.

Mobile Computing Platforms

Mobile computing platforms are the result of the continuing miniaturization of computers and the merger of computing and telephone technologies. Mobile computing devices include lighter personal computers, special purpose e-readers, and tablet computers, as well as smartphones networked through Wi-Fi or 3G/4G technologies. Applications designed for traditional Mac and Windows platforms must now take into consideration mobile devices based around the Google Android OS, Apple iOS, Blackberry OS, and a wide array of proprietary systems, many built around the Linux operating system. The proliferation of mobile computing devices has dramatically increased opportunities for multimedia developers while also posing the challenge of creating applications that meet the requirements of a variety of mobile platforms.

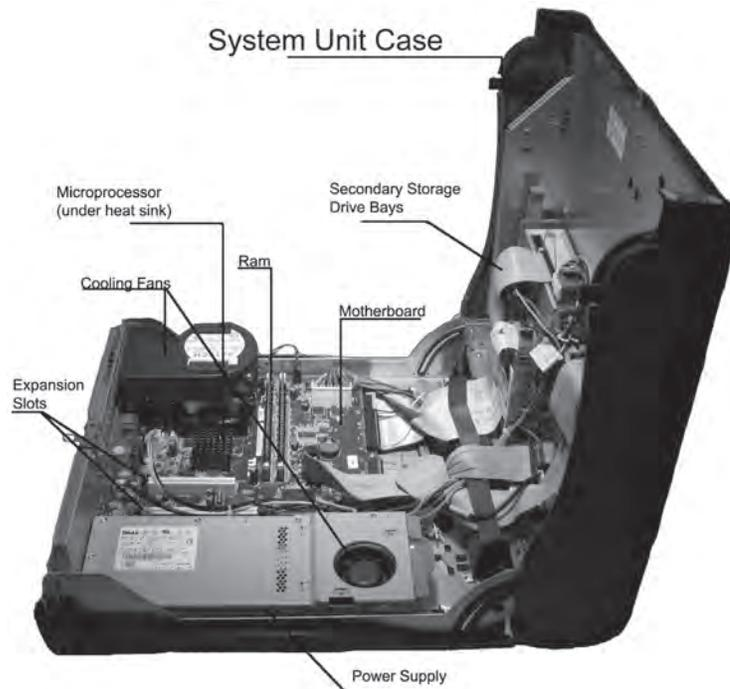

Figure 3.2 System unit.

3.3 Computer Hardware Basics

Computer hardware is divided into two main categories: the system unit and peripherals. The **system unit** contains the electronic components used to process and temporarily store data and instructions (Figure 3.2). These components include the central processing unit, primary memory, and the system board. **Peripheral devices** are hardware used for input, auxiliary storage, display, and communication. These are attached to the system unit through a hardware interface that carries digital data to and from main memory and processors.

System Unit

Central Processing Unit The most important component of any electronic computer is the central processing unit. A **CPU** is a complex integration of millions of transistors that execute program instructions and manipulate data. The Intel 10-Core Xeon houses over 2.6 billion transistors within a tiny 2-inch chip. This ability to store a CPU on a single silicon chip ushered in the age of personal computers.

The CPU has three essential sets of transistors that work together in processing digital data: a control unit, an arithmetic logic unit, and registers. The **control unit** directs the flow of data and instructions within the processor and electronic memory. The **arithmetic logic unit (ALU)** contains programmed transistors

The System Unit and the Box

Many refer to the rectangular box of the computer as the system unit. In fact, that “box” can contain several peripheral devices such as hard drives, optical drives, and even the monitor. As computer sizes shrink, manufacturers combine peripherals with the system unit in a single container.

that perform mathematical and logical calculations on the data. The **registers** are special transistors that store data and instructions as they are being manipulated by the control unit and ALU. New microprocessors also have additional high-speed memory called **cache**, on the chip to store frequently used data and instructions.

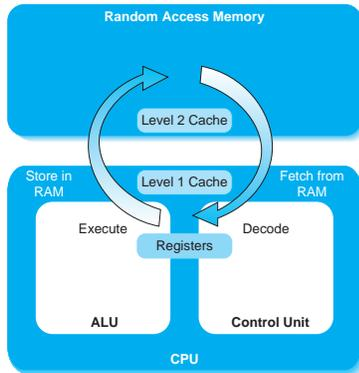

Figure 3.3 Sequential processing steps.

Processing data and instructions are managed in a machine cycle. The **machine cycle** includes four steps that a processor carries out for each instruction: fetch, decode, execute, and store (Figure 3.3). The control unit *fetches* data and instructions from a part of the computer's memory called RAM (random access memory). It transports the digital bits through an electronic bus, stores the instruction in registers, and *decodes* the instruction for the arithmetic logic unit. The ALU *executes* the instruction and returns the result to an accumulator register and storage register. When one machine-level instruction is completed, a second one is sent through the cycle. Eventually there is an instruction to *store* the results and the control unit moves data from its temporary storage register to a specific address in RAM. Various performance features of the CPU determine the efficiency of this basic machine cycle. These include clock speed, word size, bus width, and techniques such as pipelining, RISC processing, multiprocessing, and multicore technology.

Clock Speed An internal system clock synchronizes the machine cycle. On each clock tick, the CPU executes another instruction. **Clock speed** is the rate at which the CPU carries out its basic instructions. Computers execute instructions very rapidly, at speeds measured in hertz. One *hertz* is one cycle per second. Microcomputer clock speed is measured in *megahertz* (MHz, millions of cycles/second) or *gigahertz* (GHz, billions of cycles/second). Newer chip set designs combined with faster electronic storage are making it difficult to rate CPU performance solely on clock speed (Table 3.1). Increasing internal clock speed is just one method of improving the performance of a CPU. Other performance features must also be optimized to take full advantage of the processor's power.

Word Size One important factor that contributes to CPU power is the amount of data or instructions that are moved through a processor in one machine cycle. **Word size** refers to the group of bits that a processor can manipulate as a unit in one machine cycle. A 64-bit processor can manipulate 64 bits (or 8 bytes) of data at one time, clearly an advantage over a 32-bit (4 bytes) processor.

Table 3.1 Sample Processor Ratings

Microprocessor	Transistors	Clock Speed	Word Size
Intel Pentium IV	42 million	2.4 GHz	32 bit
AMD Athlon64	105.9 million	2.2 GHz	32 bit
AMD K10	758 million	1.6 GHz	64 bit
Intel i7 Quad	731 million	2.93 GHz	64 bit
Intel Atom Z540	47 million	1.86 GHz	64 bit
Intel i7 Six Core	2.2 billion	3.9 GHz	64 bit

replace them with a simpler set of instructions for executing the most common commands used by the processor. These common commands are combined to carry out the less frequent, more complex processing tasks. This results in faster overall processing of routine operations. RISC technology is found in many microprocessors and is rapidly expanding to mobile phone processors.

Multiprocessing Multiprocessing can also improve system performance. **Multi-processing** is a combination of multiple processors on the system board that execute instructions simultaneously. There are several approaches to multiprocessing. Computers

Microcode is a programming technique for implementing the instruction set of a processor. An **instruction set** is the set of instructions that a processor can carry out.

may have a CPU and math coprocessor or graphics coprocessor working together to increase the overall performance of a system. The Apple G5 computer has dual processors that speed CPU operations using 64-bit chips, reaching processing power comparable to a supercomputer. Multimedia development may also employ **parallel processing**, a technique of linking multiple processors to operate at the same time on a single task. Parallel processing is often used to speed the final stage of 3-D animation, known as rendering. Dreamworks employed a “render farm” of over 1000 HP ProLiant DL145 servers to render the daily versions of its animated films *Shrek 2* and *Madagascar*.

Multicore Technology Multicore processors are an increasingly popular approach to multiprocessing in personal computers. A processor core is a CPU’s “computational engine,” that is, those components that directly execute instructions. Older processors were single core. The CPU was built around a single computational engine that fetched and executed each command in the pipeline as fast as it could. To improve processing capacity, engineers increased clock speeds and made other improvements that added transistors to the CPU. However, the extra electronics increased the heat on the chip and did not achieve the performance gains necessary for current computing demands. Manufacturers looked for a different strategy to increase processing speeds while reducing heat and improving energy efficiency. The result was the multicore architecture.

Multicore technology combines two or more processor cores and cache memory on a single integrated circuit. A dual-core processor has two execution cores and two L2 memory caches. These two “cores” work together simultaneously to carry out different tasks. More cores can be added to further improve computer response time for increasingly complex operations. To achieve these computing gains however, the operating system and applications must be adjusted to take advantage of the multiple cores using a technique called multithreading, or passing tasks simultaneously to different cores to execute.

Multicore processors can significantly improve performance in multitasking work environments where one processor core can address one task while a second task is completed by another core. For example, one core might be directed to writing a DVD and a second one to editing images in Photoshop. A multicore processor would execute both tasks faster because each core could address a separate task. This can speed the process of multimedia development. The technology also has benefits for multimedia playback, particularly for graphics-intensive applications. Multicore processors are used

in many video gaming consoles where they speed real-time rendering of complex graphics and player interactions.

The fetch/execute cycle of the CPU is optimized by a variety of techniques to increase speed and deal with more complex data types. By increasing clock speed, word size, and the system bus, the control unit and ALU can process data faster. New developments in pipelining, multiprocessing, and multicore chips are producing faster processors that can handle increasingly complex commands for manipulating multimedia data.

Research continues to improve the speed and performance of the CPU. Moore's Law suggests that manufacturers can double the speed of a processor every 18 months. Future computers may use nanotechnology to achieve smaller and faster processors. Reliance on electronics may be replaced with optical circuitry to increase the speed of processing to "light speed." Whatever the technique, we can expect new computer processors to continue to show improvements in performance.

Nanotechnology: Manufactured objects are designed and built by the specification and placement of individual atoms or molecules.

Primary Memory Modern computers operate with electricity. The CPU processes electrically and uses basic instructions wired in the ALU's electronics. Therefore, data and instructions directly manipulated by the CPU must also be stored electronically. **Primary memory** is electronic storage that is directly addressed by the CPU.

There are several forms of primary memory on a computer system. **Random access memory (RAM)** consists of addressable storage areas for data and instructions in electronic format. This storage is volatile. Once electricity is powered off, the contents are lost. While not suitable for long-term storage, RAM provides the fast, electronic access to data and instructions required for processing by the CPU.

The amount of RAM storage is an important performance feature of computer systems. RAM is measured in units of megabytes (MB) or gigabytes (GB). Personal computers used to develop and play complex multimedia should have as much installed RAM as possible. Large RAM capacities are necessary to store the operating system, application software, and data for multimedia processing. Modern multimedia operating systems use large amounts of electronic storage. Current operating systems from Apple and Microsoft recommend 2 GB of RAM. The application software to develop media also has large memory requirements. Developers like to keep more than one program open in memory. This practice of **multitasking** (running more than one program simultaneously) consumes large amounts of RAM. In addition, multimedia data files are often very large. Sound and video files, for example, can easily require 500 MB or more of electronic storage. Larger capacities of RAM storage mean more data and applications can be open and readily accessed by the CPU. This translates to greater efficiency in the development and delivery of multimedia applications.

A second form of primary memory is **read-only memory (ROM)**. ROM is a special form of nonvolatile electronic storage that contains frequently used instructions for the CPU. These commands are hardwired or embedded in the chip by the manufacturer; they can be read, but not changed. The instructions perform essential system checks and load the operating system from disk storage into RAM. ROM is activated when the power is on. The embedded instructions do not disappear when the power is off, unlike RAM storage.

A third form of electronic memory is called cache storage. This high-speed electronic storage optimizes microprocessor speed by storing frequently used data and instructions close to the processor. This reduces the time it takes to locate and transport data from RAM. Primary cache (Level 1) is on the actual CPU chip. Level 2 cache is positioned between the CPU and RAM. It has higher capacity than primary cache on the CPU, but less capacity than RAM. Neither Level 1 nor Level 2 cache storage adds to the overall total of available RAM. However, cache is an important feature that improves processor performance.

System Board The **system board** (also called the *motherboard*) is the main circuit board, or the electrical foundation of the computer. In addition to CPU, RAM, and ROM chips, the system board contains the following:

- Expansion slots to add memory and hardware devices
- Special purpose chips that convert analog signals to digital format
- Video card to control the display monitor
- Power supply
- I/O interface ports to capture and send data to peripheral devices

Multimedia computers are equipped with many built-in devices, but often a developer may want additional hard drives, a DVD burner, or a second video board, for example. Many computers have expansion slots to add these hardware components; others have limited or no expansion capability at all. An alternative to adding devices directly on the system board is to plug external devices into an interface port.

Hardware Interface A **hardware interface** is a point of union between the system unit and a peripheral device. Data flows through the interface between the system board and peripheral devices in a serial or parallel path. **Serial data transmission** is a single stream of bits. One wire sends the bits and another wire returns the bits. This method is generally used for devices that don't transfer large volumes of data, such as a keyboard, mouse, or modem. **Parallel data transmission** is a series of bits transferred simultaneously. Each bit has its own wire in a parallel path. Parallel connections may move 8 or more bits of data at once, thus increasing the amount of data transferred in a given amount of time. **Interface ports** are connections to add peripheral devices to the system board (Figure 3.5). They are generally located behind the system unit cabinet or on the sides of portable computers. Current microcomputers are equipped with USB (Universal Serial Bus), FireWire (IEEE 1394), audio, video, and Ethernet ports.

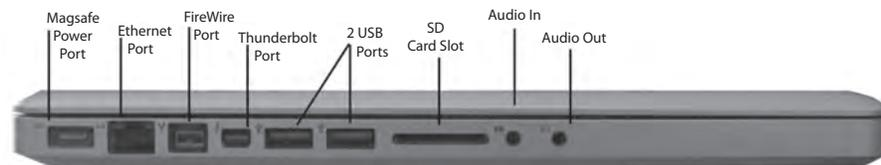

Figure 3.5 Interface ports for MacBook Pro.

Universal Serial Bus (USB) is an input/output bus to transfer data at higher speeds than older serial and parallel interfaces. USB has several advantages over previous bus systems. First, it is a widely supported standard. This simplifies purchasing external devices. A USB device can plug into any USB port, whether on an Apple or PC. Second, a USB cabling system creates its own independent bus where up to 127 devices can be daisy-chained together and share a single port on the microcomputer. Third, USB devices are “hot swappable.” A USB device can be disconnected and another device swapped (plugged) into the system without restarting the computer. Fourth, USB devices can be powered through the interface port rather than a separate power supply. This greatly reduces the number of power adapters (or “wall-warts” as they’ve been called) that clog up power strips. Finally, USB has faster data transfer. USB transmits data at speeds of 12 Mbps (megabits per second) compared to the RS-232C speeds of 115.2 Kbps (kilobits per second). USB devices such as printers, scanners, zip drives, and keyboards benefit from faster transmission rates. The USB 2.0 standard introduced even faster transmission rates (480 Mbps) for devices that require higher rates of transmission such as MP3 players, removable hard drives, and DVDs.

IEEE 1394 (named **FireWire** by Apple) is a high-speed serial interface standard with data-transfer rates of 400 Mbps over cables up to 4.5 meters in length. It has its own bus system that can daisy chain up to 63 devices. Like USB, FireWire devices are hot swappable and power for these devices is drawn from the FireWire port. These ports are most often found on digital video cameras or large capacity external hard drives. A further development of the standard, FireWire 800, has twice the transfer speed and can maintain it across 100-meter cables. This opens efficient cabling possibilities to capture digital video and/or audio from cameras placed significant distances from the computer (Figure 3.6).

As the processing speed of CPUs increases, computer manufacturers continue to seek ways to increase the interface speeds between the user and the system board. **USB 3.0** and **Thunderbolt** are the newest interfaces for connecting peripheral devices to the system board.

Code named *SuperSpeed* USB, the USB 3.0 standard offers faster transfer speeds than its predecessors. USB 3.0 can deliver up to 4.8 Gbps and remain backward compatible to the USB 2.0 standard. High-bandwidth devices such as camcorders, webcams, and Blu-ray burners, for example, will experience better performance using the USB 3.0 interface.

Thunderbolt was developed by Intel and introduced to the market by Apple. It offers three main advantages over other interfaces. First, Thunderbolt combines the transfer of both computer data, from devices such as hard drives, and display data for additional monitors or projectors. This simplifies the interface by eliminating the need for a separate video port. Second, Thunderbolt improves transfer speeds. It delivers simultaneous data and display transfer on a single bidirectional cable at speeds of 10 Gbps, making it the fastest entry into computer interface design. Finally, Thunderbolt increases the



Figure 3.6 USB, FireWire, and Thunderbolt cables.

Table 3.2 Transmission Rates for Common Interface Standards

Serial Port	115 Kbps
Standard Parallel Port	115 KBps
USB	12 Mbps
USB 2.0	480 Mbps
USB 3.0	5 Gbps
IEEE 1394 or FireWire	100–400 Mbps
FireWire 800	800 Mbps
Thunderbolt	10Gbps

power available to peripheral devices to 10 watts compared to USB 3.0's 4.5 watts. Table 3.2 summarizes transmission rates for the various standards.

Peripheral Devices

Peripheral devices are the hardware components that input, output, and permanently store data and applications for computer processing. Although often located close to the system unit, they are outside the main processing circuitry and thus are considered peripheral (Figure 3.7). The functions and performance characteristics of peripherals are important considerations both for multimedia users, who may want the best display device for a video game, and for developers, who seek high-performance data capture and access.

Secondary Storage Devices Computer systems are not complete without a means of storing data and instructions for future use. Random access memory is essential for the CPU to process data and instructions electronically, but RAM is volatile. Once the power is off, memory is cleared and data is lost. **Secondary storage** is the media that holds data and instructions outside the system unit for long periods of time. It is also called *external storage* or *auxiliary storage* to distinguish it from primary electronic storage inside the



Figure 3.7 With the miniaturization of today's mobile computing devices, the peripherals may not seem so distant. Smartphones and tablet computers embed display and input into the single system device.

system unit. Early forms of secondary storage were paper tape, punched cards, and magnetic tape. Secondary storage now includes hard disks with gigabyte capacities, optical discs that deliver high-fidelity multimedia, and a wide array of portable storage ranging from zip disks to flash drives, as well as portable music players and smartphones (Figure 3.8).

Secondary storage has several advantages over primary electronic storage. In addition to being nonvolatile, secondary storage is easily expandable and portable. If one disk fills with data, another disk is readily available. Data and applications are easily distributed and shared through secondary storage media such as CDs, DVDs, flash drives, or zip disks. Each of these addresses one or more of the five main uses of secondary storage: *saving, backup, distribution, transport, and archiving.*

The most obvious use of secondary storage is to *save* the data that is in electronic memory for further processing. Multimedia developers frequently save data files to hard drives or other devices as they work. They know that RAM is volatile and that hours of effort can be lost in an instant with a system crash or power failure. Important performance criteria for saving include capacity, access time, and transfer rate. **Storage capacity** is the amount of digital data, measured in bytes, that a device can record. Multimedia developers require high storage capacities for large media files such as digital video. **Access time** is the time needed to locate data on the storage device. **Transfer rate** measures the speed at which data moves between secondary storage and RAM. Faster access times and transfer rates mean less time waiting for data and applications to load into RAM. This speed is especially important if developers are working with large sound or video files where fast access to data editing and playback is essential.

Another use of secondary storage is to *back up* entire hard drives or important volumes on the hard drive. Data is a major asset for most organizations. It must be preserved in the event of damaged drives, theft, system crashes, viruses, or natural disasters. Backup systems should have large storage capacities and be able to transfer data quickly. Frequently, a hard drive is backed up to another hard drive because both have large capacities and fast transfer rates. Users should also consider backing up important data files to other devices, such as a zip disk, flash drive, or DVD, on a routine schedule. To further protect the data, the backup should be stored in another location, preferably off-site.

A third use of secondary storage is *distribution* of data and applications. Networks improve data sharing over communication lines, but data portability cannot be restricted to network connections. Data and applications can also be distributed by “snail mail” or as retail products such as “shrink-wrap” software. CDs, for example, are cheap to produce, have long storage life, and are lightweight. Most computers can read the disc, which makes them a good choice to distribute applications and data. Performance features to consider in distributing secondary media include cost, weight, data integrity, and adherence to standards for playback.

In addition to distributing data and applications, secondary storage media *transport* digital content. Commonly called “sneaker-net,” users can carry their digital files on por-



Figure 3.8 The iPod is also a popular storage device. In addition to holding hours of music and video, the iPod can plug into a USB port to record data for transport.

table media such as flash drives. Adequate capacity and the ability to withstand temperature extremes, magnetic fields, and the wear and tear of a duffel bag are important criteria for digital data on the move.

Finally, a fifth use of secondary storage is to *archive* digital information for long-term preservation. Digital files abound in all the transactions of daily life, and schools, hospitals, governments, businesses, and other organizations must preserve them for legal and historical purposes. In the past, this meant large vaults of file folders. Later, these files were transferred to tape and stored in special tape libraries. Archived data requires storage media with massive and expandable capacity, media longevity, and security. These include RAID (redundant array of independent disks) drives, WORM (write once, read many) optical disk library systems, and digital tape.

The secondary storage devices fall into three broad categories based on the underlying technology used to represent digital data: magnetic, optical, or solid state.



Figure 3.9 Zip cartridges.

Magnetic Storage **Magnetic storage** devices record and/or read digital content in magnetic form. Early microcomputers used floppy disks for magnetic storage. These were thin plastic disks with a coating of iron oxide that could be inserted in a floppy drive mechanism. They were light and easily transportable but very limited in storage capacity (1.4 MB per disk). Later, cartridge drives such as the zip drive provided removable media with larger capacities (100 MB, 250 MB, and 750 MB) (Figure 3.9). Although zip cartridges and similar media are still in use, they have largely been replaced with solid-state devices such as USB flash sticks. Magnetic storage is now found principally in internal and portable hard drives.

Hard drives are composed of rigid platters mounted on a spindle in an enclosed drive container. The container regulates air pressure and filters the air that enters the drive to protect it from dust and other contaminants. A drive motor rotates disks at speeds of 7200 revolutions per minute (rpm) or more.

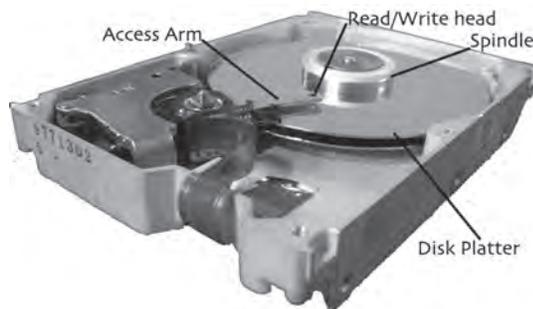

Figure 3.10 Disk platters are rotated on a spindle. The access arms move to a track location and the read/write head transfers data to and from RAM. Source: © vadim kozlovsky/Shutterstock, Inc.

The drives record bits on a disk platter as positive or negative magnetic fields. Access arms with read/write heads move between platters to read tracks on both top and bottom surfaces (Figure 3.10). Data is stored on these platters in addressable tracks and sectors defined by the operating system. A **track** is a circular path along which data is stored. **Sectors** are pie-shaped logical divisions of a track (Figure 3.11). Each sector holds a designated amount of data (traditionally 512 bytes; more recently 4096 bytes). The number of tracks and sectors determine the drive's storage potential. Hard-disk units built inside the computer system have capacities ranging from gigabytes to terabytes, but even these disks quickly fill with large multimedia data files, applications, and modern graphics-based operating systems.

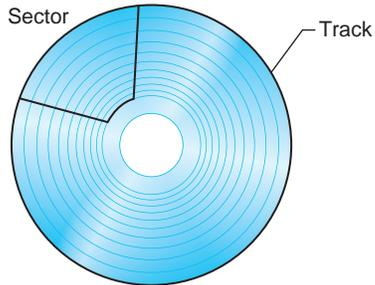

Figure 3.11 Track/sector addressing scheme for magnetic storage.



Figure 3.12 External hard drives.

External hard drives supplement the fixed hard drive capacity while providing data portability and security. These drives often use FireWire or Thunderbolt for high-speed data transfer to the system unit. They are commonly used to back up and secure data, or store and edit large projects such as digital video (Figure 3.12).

Magnetic media can provide large-capacity storage and rapid data access and transfer. Magnetic storage is also economical. Prices are currently under 10 cents per gigabyte and they continue to drop. But magnetic storage also has several disadvantages, not the least of which is its limited durability. Magnetism is easily destroyed or weakened over time, resulting in damaged or lost data unless backups are done frequently. See Table 3.3 for sample performance measures of magnetic storage.

Optical Storage **Optical storage** uses laser technology to read and write data on specially coated reflective discs. The origins of optical storage can be traced to the early 1980s.

In 1982, the CD (compact disc) revolutionized the music industry and spurred the development of multimedia applications. Philips and Sony first developed CDs to replace vinyl records with a medium that could deliver high-quality sound on a small, lightweight platter. LP (long playing) records were limited to 45 minutes of analog music. Sound quality was governed by the condition of the record and needle, and records themselves were bulky and difficult

Disc and Disk

Disc refers to optical storage media as opposed to *disk*, which is used for magnetic media.

Table 3.3 Magnetic Storage Performance Measures

Device	Access Time	Transfer Rate	Capacity
Zip drive	29 ms	1.2 MB/s (USB 250)	100, 250, 750 MB
Hard drive	< 9 ms	15 MB/s–160 MB/s	Variations of GB/s & TB/s
External hard drive	> 13 ms	20 MB/s–100 MB/s	Variations of GB/s & TB/s

to manage. Portable music was restricted to tapes, also easily susceptible to damage. Compact disc storage and digital music provided a medium for permanent, high-fidelity recordings. CDs were designed to hold a full 74 minutes of digital audio recording, significantly increasing music storage over the long-playing vinyl record.

The advent of optical storage also offered new potential for multimedia. A new CD standard, called CD-ROM, was developed especially for computer data. Now applications that required large storage could easily be distributed on a small 4.72-inch disc. The first general interest CD-ROM was *Grolier's Electronic Encyclopedia*. Released in 1985, its 9 million words only used 12% of the CD-ROM's capacity. Optical storage technology developed rapidly. From music CDs of the 1980s, technology expanded to DVD-Videos in the 1990s.

- **Compact Disc Technology:** CD storage uses a laser beam to read and write data to a disc. **Lasers** are amplified light energy focused into a very precise beam. The basic process is simple: focus a laser beam on a reflective surface and measure the amount of light reflected back on a photo detector. By altering surface texture, light will either be reflected or deflected.

Pits, Lands, and EFM

Pits and lands do not translate directly to bits. Instead, optical discs use an encoding system called *eight-to-fourteen modulation* (EFM). Fourteen bits are used to encode the 8 bits of a data byte. The extra information is used to ensure the accuracy of the optical reading of each byte.

The disc acts as a reflective mirror with pits and lands that encode digital content. **Pits** are indentations on the surface and **lands** are the flat area. Pits scatter light and lands reflect light (Figure 3.13). Binary data once encoded as positive/negative magnetism is now read as variations in light reflection.

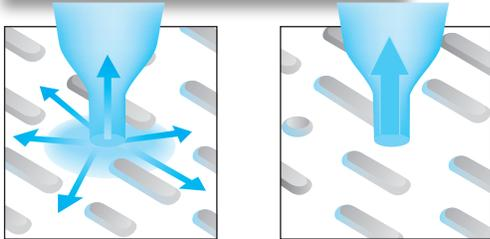

Figure 3.13 Pits scatter light and lands reflect light.

CD-Audio and CD-ROM discs are manufactured by pressing pits into a plastic base. This process is called *stamping*. A reflective layer of aluminum is then added and finally a lacquer coating is applied to protect the surface. The laser beam scans the bottom of the disc surface where pits appear as bumps to scatter light. Lands reflect the full intensity of the light beam. Once the CD is stamped, data is permanent.

Optical storage has several advantages. The first is high-capacity storage. Laser beams are extremely precise and pits and lands are extremely small, so data is densely recorded on a disc. Pits are approximately 0.83 microns long by 0.5 microns wide (about 30 times narrower than a human hair). Data is recorded in one continuous spiral from the center to the outside edge of the disc. There are about 20,000 windings of this single spiral on a CD, resulting in a total track length of 5000 meters, or about 3 miles. This produces a storage capacity of 680 MB.

Another benefit of optical storage is stability. CD data is more durable than data stored magnetically. Pits are pressed into the disc. This process makes it unlikely that normal handling and exposure to the environment will destroy the data. CD data is also encoded with special error detection and correction code (EDC/ECC) to further ensure data integrity if the disc is damaged. Magnetic disks do not incorporate error detection and correction, with the result that damaged data is often lost

data. By contrast, the data on a scratched CD-Audio disc can usually be repaired as it plays. CD technology is synonymous with high-capacity, high-quality, and durable storage.

- **Optical Data Encoding:** Optical data is organized in *tracks*, *frames*, and *sessions* on the disc. A track is the basic addressing scheme on a CD. A CD has a physical, continuous spiral from the center to the outside edge, but it is further divided into logical units called tracks. A compact disc addresses 1 of up to 99 sequentially numbered tracks. Each track can handle only one data type, so a CD with music and text would require at least 2 separate tracks (Figure 3.14).

The basic unit of information stored on a CD is a **frame**. Frames define the physical format of data. Frames contain data code, error detection and correction code, synchronization code, and information about the track. Fifty-eight frames are grouped together to form the smallest addressable data unit, called either *blocks* (CD-Audio) or *sectors* (CD-ROM). Each CD-Audio block has 2352 bytes of user data, while CD-ROM sectors contain 2048 bytes of data code. There are fewer bytes of data code on the CD-ROM because these sectors contain more error detection and correction code that helps ensure the integrity of error-sensitive media such as text and numbers.

A **session** is a single recorded segment on the CD. Sessions may cover several tracks depending on the content of the application. For each session, a track table of contents is added to the disc. A *track table of contents* (TTOC) is an index of track contents. Early CDs supported only one session and one TTOC per disc. This is called a single-session CD. Newer CD formats support *multisessions*. Kodak used the first multisession CD for their PhotoCD by recording one set of photos on a CD, then adding another set

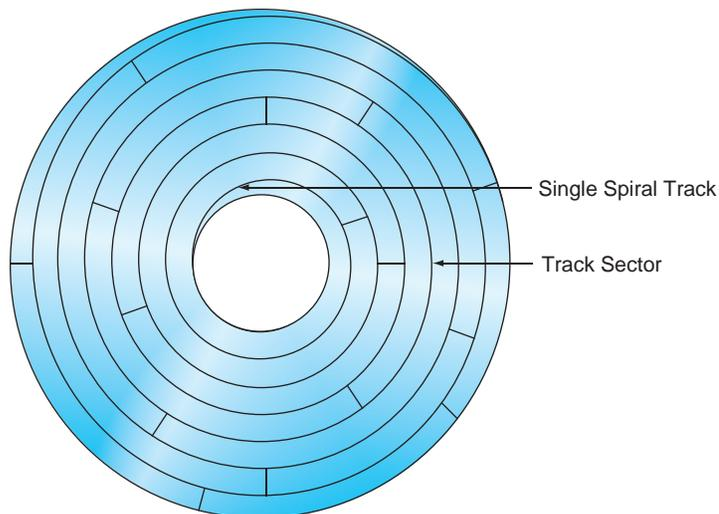

Figure 3.14 CDs store data in a continuous spiral from the center to the outside of the disc. The single spiral is further divided into logical units called tracks. The smallest addressable data unit is called a block or sector.

of images with a separate track table of contents to the same CD at a later time. Today, multisession storage is common on CD-R (CD-Recordable) discs.

- **Compact Disc Formats:** One of the more important decisions made by optical disc manufacturers was to standardize the size of the disc. Disc size is fixed at 120 mm, with a 15-mm center hole and 1.2-mm thickness. As a result, all CDs will fit into any drive, making it possible to design newer drives with backward compatibility. *Backward compatibility* is the ability of more recent hardware or software to use data from an earlier product. The most important CD formats are CD-DA, CD-ROM, CD-R, and CD-RW.

CD-ROM sectors have less data capacity than CD-Audio blocks because they contain more error detection and correction code. This helps ensure the integrity of error-sensitive media such as text and numbers.

The **CD-DA** (CD-Digital Audio) format was the first digital optical disc standard and it is still used in the production of music CDs. While these discs can typically be played on a computer CD drive, CD-DA cannot be used to record computer data. CD-DA specifies a high-quality audio file format that records 16-bit samples at a rate of 44.1 KHz.

CD-ROM was developed to take advantage of CD technology for the storage of computer programs and data. CD-ROM discs are read-only memory. They can be used to distribute prerecorded data to various computers, but computers can only read them, they cannot change content by writing to the disc.

CD-R (CD-Recordable) discs use a different method of recording “pits” to allow computers to write, as well as read, a disc. Discs are coated with a photosensitive dye. This dye is translucent when the disc is blank. Light shines through and reflects off the metal surface. When data is applied, a laser beam heats the dye and alters its molecular structure to create opaque “pits” that will not reflect light.

Several dye materials are used to create these discs, each with a different color. CD-R discs are manufactured with predefined spiral tracks and sector formatting, which determines disc capacity. CD-R discs have different recording capacities measured in minutes of music and MB of data. One common capacity is 700 MB and 80 minutes. CD-ROM and CD-R discs are similar in that once the data is written, it cannot be altered or removed.

CD-RW (CD-Rewritable) discs use a different material so the laser beam can read, erase, and write data. Discs have a special layer of phase-change chemical compound. A laser beam heats the compound and changes it either to a liquid or crystalline structure. This compound in its liquid state becomes amorphous and absorbs light. The crystalline state allows light through to reflect off the aluminum surface. These crystalline and amorphous properties remain on the disc when it cools down. These discs require a special drive with a laser that alters the heat intensity as it adjusts to read, write, and erase operations. Most computers today are equipped with a rewritable optical drive. (See Appendix A for further detail on development of standards and formats for CD storage.)

- **Optical Drives:** Optical drives are complex mechanical devices that move a laser light along a track on the disc. The laser reflects light back to a system of mirrors that direct reflections to a photo detector. A tracking mechanism controls the location of the laser beam on the disc (Figure 3.15). Early optical drive motors varied rotational speed from 500 rpm when the light was at the center of the disc, to 200 rpm when the light was at the outer edges. This allowed the drive to maintain a constant data-transfer rate.

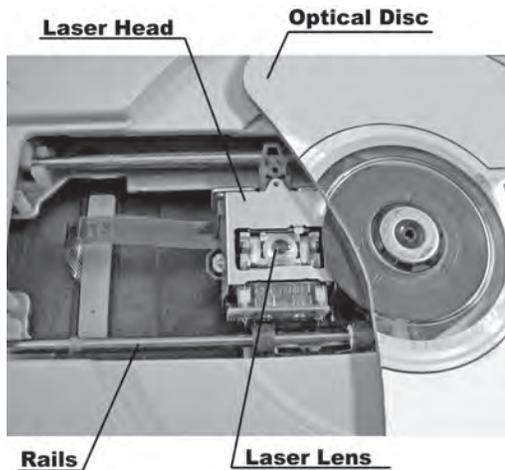

Figure 3.15 A beam of light produced by a laser is directed through a series of lenses until it is focused on the surface of the spinning disc. A drive motor moves the laser head along the rails to reposition the laser lens.

Transfer rate measures the speed at which data is moved to the computer or other device for playback. The CD-DA standard established a transfer rate of 0.15 MB/s or 1X. This ensured accurate playback of digital music. Altering this speed would distort the sound by speeding it up or slowing it down.

When CD technology was adapted for computers, higher transfer rates were needed to quickly move data from disc to RAM. One technique to produce higher transfer rates is increasing rotational speed. Current computer CD drives have transfer rates of 48X to 64X. If the drive is rated at 48X, the transfer rate is 48×0.15 MB, or 7.2 MB/s. Transfer rates are affected not only by rotational speeds, but also by the method used to store and access data on disc. There are two methods to locate and transfer data: CLV and CAV.

CD-Audio drives read data from discs at a **constant linear velocity (CLV)**. A CLV disc stores pits and lands as closely together as possible in a uniform, continuous spiral from the center to the outside edge. This produces the highest possible storage capacity, but it also creates a problem. Because disc diameter is larger at the outside, a constant rate of spin will result in more data being read per second at the outer edge than at the inner edge. To keep the transfer rate constant, CLV drives spin the disc faster when data is being read toward the center of the disc and slower as reading takes place toward the outside. This results in the same length of the data spiral being read each second, regardless of its location on the disc (hence, constant *linear* velocity). For audio data, varying disc spin rate is a reasonable mechanical adjustment because the rate of music playback is continuous and predictable from one song to the next.

Using CLV for computer data, however, poses a problem. An important performance feature of computers is random access. **Random access** is the ability to quickly read data from any location on the storage device. Random access is difficult to achieve with CLV because drives must constantly adjust spin rates depending on data location,

speeding up if the data is located close to the center and slowing down if it is closer to the outside of the disc. When CD drives were first adapted for computer data, they maintained the CLV standard but increased the motor spin rates to improve transfer rates from 1X to 12X. However, it became apparent that CD drives needed to dramatically increase rotational speeds to keep up with faster processor demands. It was reasonable to alter spin rates from 200 rpm to 500 rpm, but much harder to go from 5000 rpm to 12,000 rpm. A second method of storing and accessing data was needed.

Computer optical drives adopted the same technique used in hard drives, **constant angular velocity (CAV)**. These drives spin the disc at a constant high speed regardless of the location of the laser. Transfer rates vary from the inside to the outside track. While this would destroy playback of a symphony orchestra on a CD player, computers can compensate for the data flow variations by buffering data and storing it in RAM for later processing. Today, most CD drives that exceed 12X transfer rates are using CAV to control disc spin rate. Computer optical drives may also combine CLV and CAV techniques. CLV mode is used to write CD-Rs and CD-RWs, while CAV mode is used to read discs.

The transfer rates of current optical drives are still slower than a hard drive, but they are much faster than the original CD-Audio drives. CD-R and CD-RW drives have a range of transfer rates. CD-R has a write transfer rate and reading transfer rate. CD-RW drives have different rates for writing, erasing, and reading. A 52X–24X–52X drive will write and read at a 7.8 MB/s transfer rate, but erase at a slower 24X, or 3.6 MB/s (Table 3.4).

- **DVD: Movies and More on Disc:** The music industry sought ways to improve on vinyl records with the first CD. In similar fashion, the movie industry pushed development of DVDs to record full-length films on a higher-quality medium than film or tape. CDs held promise for video, but their storage capacity was too low for a 133-minute movie, even with high levels of data compression.

DVD, or digital versatile disc, first appeared in 1997. Originally, it was targeted as a storage format for movies and called the digital *video* disc, but developers soon recognized its potential to store all forms of digital data and changed the name to “versatile.” The versatility of DVD is reflected in its various designations: *DVD-Video* for motion pictures, *DVD-Audio* for high-quality music, *DVD-ROM* for distribution of computer software. Competing standards and other uses of the technology have led to a proliferation of DVD specifications. See Table 3.5 for a listing of the most significant of these formats.

The main advantage of DVDs over CDs is storage capacity. The capacity of a CD is approximately 650 MB. A DVD can hold up to 17 GB. The higher capacity of DVDs is

Table 3.4 CD Drive Rotational Speeds and Transfer Rates

Drive Rating	Access Method	Avg. Transfer Rate (MB/s)	RPM
1X	CLV	0.15	200–500
8X	CLV	1.2	1600–4000
12X	CLV	1.8	2400–6000
20X	CAV	3.08	4000
40X	CAV	6.15	8000
56X	CAV	8.6	11,200

based on four major developments: a more precise laser light, multilayer storage, new video compression algorithms, and improved error detection and correction code.

DVDs and CDs are the same physical size and share the same basic optical storage technology. But new lasers with a wavelength of 635 to 650 nanometers and powerful laser lens systems can focus on smaller pits to significantly increase storage capacity. DVD pits have a minimum length of 0.40 microns, compared to the CD's 0.83 microns (Figure 3.16). Data is recorded on a spiral

4.7 GB of DVD storage can hold:

- More than 400,000 text documents, the equivalent of eight 4-drawer filing cabinets stuffed with paper information
- 4700 full-color digital photos @ 640 × 480 resolution
- 210 minutes, a full 3.5 hours of compressed MPEG2 satellite-quality video
- 120 minutes of compressed MPEG2 theater-quality video
- 14+ hours of MP3 compressed audio

Verbatim Corp.

Table 3.5 DVD Formats

Format	Features	Players
DVD-ROM	Read only format Video or game content burned into the DVD First standard	Runs on any DVD-ROM equipped device
DVD-Audio	Higher-quality sound than CD 192 kHz/24 bit 74 min high-quality sound 7 hrs CD-quality sound	Requires special player to read the higher-quality sound files
DVD-RAM Supported by Panasonic, Toshiba, Apple, Hitachi, NEC, Pioneer, Samsung, and Sharp	Writable DVD formats for use in computers Rewrite more than 100,000 times Life expectancy about 30 yrs	Removable storage for computers Not compatible with most players
DVD-R Supported by Panasonic, Toshiba, Apple, Hitachi, NEC, Pioneer, Samsung, and Sharp	Writable DVD discs using organic dye technology 4.7 GB	Compatible with most DVD drives and players
DVD-RW Supported by Panasonic, Toshiba, Apple, Hitachi, NEC, Pioneer, Samsung, and Sharp	Phase-change erasable format 4.7 GB Rewrite about 1000 times Drives write DVD-R, DVD-RW, CD-R, CD-RW discs	Playable in many DVD drives and players
DVD+RW Supported by Philips, Sony, HP, Dell, Ricoh, and Yamaha	Erasable format Holds 4.7 GB/side Writes in a way compatible with many existing DVD readers Rewritten about 1,000 times	Readable in many DVD-Video players and DVD-ROM drives
DVD+R Supported by Philips, Sony, HP, Dell, Ricoh, and Yamaha	Record only in CLV mode A write-once variation of DVD+RW.	Readable in many DVD-Video players and DVD-ROM drives
Blu-ray Developed by Sony, Samsung, Sharp, Matsushita, Pioneer, Mitsubishi, and LG Electronics	Rewritable disc Transfer rates of 36 Mbps Up to 25 GB on single layer, 50 MB on dual layer disc 9 hrs of HD video or 23 hrs of standard video	Plays in game consoles and home theaters and can support all the disc-based media

Adapted from www.dvdmystified.com/dvdfaq.html#4.2

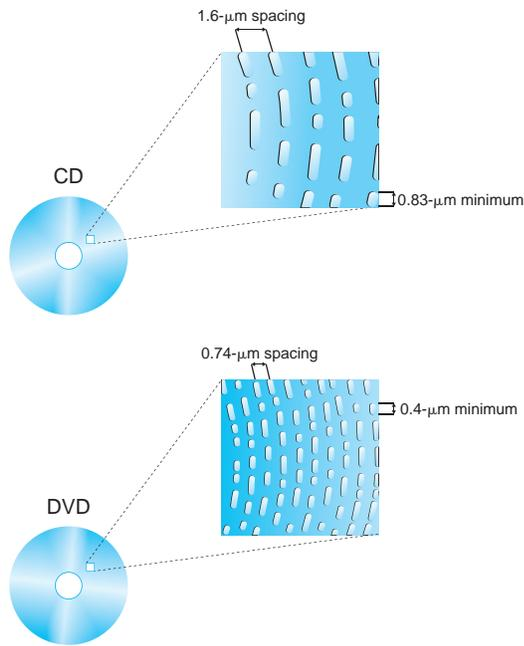

Figure 3.16 Pits are closer together on a DVD disc.

track that measures 7.5 miles, as compared with the CD's 3 miles. Each layer stores 4.7 GB of data, two layers on the same side offers 8.5 GB of storage. When all four layers are used, a total of 17 GB is available, enough storage for 8 hours of movies.

The second factor contributing to increased capacity is multilayer storage. Each side of a DVD can be divided into two layers. A DVD disc is a lacquer-coated sandwich of polycarbonate plastic, aluminum, and semireflective gold. The plastic is impressed with pits arranged in a continuous spiral of data. A coating of aluminum is added to the inner layer and a layer of semireflective gold is used for the outer layers. This provides two reflective surfaces. The laser first focuses on the outer layer of semireflective gold, then the lens mechanism focuses through the semireflective layer to the second layer of aluminum.

DVD players first appeared for commercial use as stand-alone systems to play DVD-Videos. Each disc could hold 133 minutes of video and an assortment of video add-ons such as trailers and outtakes. DVD drives with the capability of also handling CD and CD-RW formats were soon developed for use in computers.

The drive is similar to a CLV CD. The motor rotates the disc from 200 rpm to 500 rpm to maintain a constant data-transfer rate. A tracking mechanism moves the laser along a spiral track. It starts at the center and moves to the outside edge of the outer layer, then works from the outside back to the center on the inner layer to optimize the drive action.

DVD drives are rated according to rotational speeds (4X, 12X, etc.) just like CD drives, but the actual transfer rates are much higher for DVD drives. For example, a 1X DVD-ROM drive transfers 1.321 MB/s (as opposed to the 0.15 MB/s of CDs). A 6X DVD drive transfers approximately 7.93 MB/s, equivalent to a 54X CD drive. There is no advantage to a 6X DVD player for playing movies. Speeds above 1X do not improve video quality, but they will impact the speed for reading computer data and playing games.

Despite a DVD's impressive 17-GB capacity, a single disc still cannot accommodate the 110 GB required for an uncompressed full-length movie. The third improvement, video compression, delivered movies on a DVD. Video compression reduces file size without compromising the quality of video content. The Motion Picture Experts Group (MPEG) developed a 40:1 compression ratio for MPEG2. This compression format, combined with the storage capacity of the DVD, now makes it possible to have movies and much more on a single disc.

Finally, DVDs also benefited from improved error detection and correction code. On a CD, EDC/ECC may take up as much as one-third of the available storage space. DVDs reduce this to approximately 13%, making more disc space available for data.

DVDs have such extensive storage that manufacturers often package additional content with their films. Dolby Digital surround sound, sound tracks presented in up to 8 languages, subtitles in up to 32 languages, as well as related content such as actor profiles and alternative endings can be easily accommodated by DVD storage. Some production companies even plant “Easter eggs.” These are hidden movie clips that are not on the index. You can explore the world of DVD Easter eggs at <http://www.dvdeastereggs.com>.

The DVD gained acceptance as a medium to distribute movies, but a wide array of applications soon followed for this high-capacity disc. Basic DVD formats were applied to the music industry (DVD-Audio) and read/write computer drives. DVD formats include DVD+RW, DVD+RAM, DVD-R, and DVD-RW, but not all of these formats are compatible. Successful playback of a DVD recording will depend on the type of disc, recording drive, and the playback device.

The DVD standard introduced massive storage capability using a laser beam that was more precise than that used to create CDs. Full-featured digital video was now possible on these discs but manufacturers were not satisfied with a mere 17 GB of storage. HDTV programming and video games could benefit from even higher capacities and a new form of laser made that possible. **Blu-ray** disc (BD), developed at Sony, holds 25 GB on a single side. These storage densities are possible because a blue-violet laser has a shorter wavelength than the red laser used to record DVD discs. The result: as much as 50 GB on dual-layer discs or about 9 hours of high-definition video and 23 hours of standard definition video on Blu-ray discs.

Solid-State Storage A **solid-state storage** device is a form of computer memory that contains no moving parts. Solid-state secondary storage is nonvolatile memory that can be both read and written to. The use of solid-state devices for secondary storage has grown dramatically as their capacity has increased and their cost has fallen. Common examples include USB **flash drives**, **memory cards**, and the built-in memory used in MP3 players, digital cameras, and mobile phones. The technology used in all these devices is called **flash memory** (Figure 3.17).

Flash memory is made up of a grid of cells, each of which contains two transistors. A very thin layer of insulating oxide separates the transistors. One serves as a *control gate*. The other is a *floating gate*. The insulating oxide layer traps any electrons present on the floating gate, preserving the electronic information with no need for external power. The charge of the floating gate, in turn, modifies the electric field of the control gate. The voltage of this field is then read to determine the bit value (0 or 1) of the cell.

Solid-state memory has a number of advantages. The absence of delicate mechanical parts makes solid-state storage more durable. They are smaller and weigh much less than their mechanical counterparts. Finally, solid-state devices use less power.



Figure 3.17 Solid-state storage devices have a variety of names. Memory stick, thumb drive, and travel disk are commonly used. The standard name is USB flash drive or “UFD.”

These benefits will lead to increasing use of flash technology for secondary storage. Mechanical storage is not likely to be completely replaced, however. Flash storage is more expensive than magnetic and optical storage, and the capacities of most flash devices are significantly smaller. But perhaps the biggest concern is that flash memory has a limited life expectancy. In general, the average flash drive lasts between 10,000 and 100,000 write/erase operations. Environmental damage, manufacturer defects, and human error also reduce the flash drive's life span. As a result, magnetic, and especially optical, devices are currently the preferred media for long-term storage.

Storage in the Cloud A popular alternative to secondary storage devices is to store and manage data on a remote server. Storage in the cloud has gained popularity with the increase in Internet access, mobile computing devices, and high bandwidth connectivity. **Cloud storage** is a service provided through a network (usually the Internet), either free or fee based, to back up, maintain, and manage data remotely. It offers convenient access to data from any place on any networked device. This portability and ubiquitous access has made such platforms as Google Docs, Apple iCloud, and Microsoft SkyDrive popular alternatives to secondary devices where data remains locally controlled and managed. Many providers of cloud services offer unlimited storage capacity and the ability to share data with other users. However, this storage service does raise security and reliability concerns. Without a consistent Internet connection, a user will not have ready access to the data. Protection of the data is subject to the practices of the provider. Should the cloud service go out of business, data recovery may be difficult. Despite the convenience of storing data on a remote server, multimedia developers should thoroughly research the reliability of the service provider before entrusting data to the cloud.

Input Devices for Multimedia Computers

Multimedia requires a variety of input devices to transmit data and instructions to a system unit for processing and storage. Keyboards and pointing devices, such as trackballs, touch pads, and touch screens, are central to interacting with graphical user interface (GUI) applications and operating system software. Other devices are necessary to input sound, video, and a wide array of images for multimedia applications. Some of these, such as microphones, are built into the system. Others, such as scanners, cameras, sound recorders, and graphics tablets, are plugged into USB or FireWire interface ports.

Scanners capture text or images using a light-sensing device. Popular types of scanners include flatbed, sheet fed, and handheld, all of which operate in a similar fashion: a light passes over the text or image, and the light reflects back to a **CCD** (charge-coupled device). A CCD is an electronic device that captures images as a set of analog voltages. The analog readings are then converted to a digital code by another device called an **ADC** (analog-to-digital converter) and transferred through the interface connection (usually USB) to RAM.

The quality of a scan depends on two main performance factors. The first is **spatial resolution**. This measures the number of dots per inch (dpi) captured by the CCD.

Consumer scanners have spatial resolutions ranging from 1200 dpi to 4800 dpi. High-end production scanners can capture as much as 12,500 dpi. Once the dots of the original image have been converted and saved to digital form, they are known as pixels. A **pixel** is a digital picture element.

The second performance factor is **color resolution**, or the amount of color information about each captured pixel. Color resolution is determined by **bit depth**, the number of bits used to record the color of a pixel. A 1-bit scanner only records values of 0 or 1 for each “dot” captured. This limits scans to just two colors, usually black and white. Today’s scanners capture 30 to 48 bits for each pixel. This delivers a wide range of color possibilities for each pixel, making it possible to produce high-quality digital versions of photographs, paintings, and other color images.

Scanners work with specific software and drivers that manage scanner settings. Spatial resolutions and bit depth can be altered for each scan. These settings should reflect the purpose of an image. For example, if an image is a black and white photo for a website, the scanning software can be adjusted to capture grayscale color depth (8 bit) at 72 dpi. This produces an image suitable for most computer monitors that display either 72 or 96 pixels per inch. Scanner software also has settings to scale an image and perform basic adjustments for tonal quality (amount of brightness and contrast).

Optical character recognition (OCR) is the process of converting printed text to a digital file that can be edited in a word processor. The same scanners that capture images are used to perform OCR. However, a special software application is necessary to convert a picture of the character into an ASCII-based letter. This OCR software recognizes the picture of the letter C, for example, and stores it on the computer using its ASCII code (01000011). These characters are then edited and reformatted in a word processing application. Many image scanners today are shipped with OCR software that can recognize basic text formations. Specialized applications, such as OmniPage or Readiris Pro, are optimized to deliver high-speed, accurate OCR results. The final success of any OCR conversion depends on the quality of the source material and the particular fonts used on the page. Small print on wrinkled, thin paper will not deliver good OCR results.

OCR scanning is one method of capturing text documents. Scanners are also used to create a PDF (Portable Document Format) file. The scanner captures a specialized image of the page and saves it as a .pdf file. Adobe Acrobat Reader is necessary to view the contents of a .pdf file. This file format is cross-platform compatible, so it is particularly suitable for distributing highly formatted documents over a network. OCR scanning creates a file that can be edited in any word processing application. PDF scanning, on the other hand, creates a specialized file format that can only be managed by Adobe Acrobat software.

Flatbed scanners are configured to meet a variety of uses. The scanner bed varies to handle standard letter- to legal-size image sources. Multifformat holders are available for 35mm filmstrips and slides (Figure 3.18). Some scanners have an optional sheet-feed

Need a larger image? Scale when you scan. Scaling during scanning captures more information from the original image. Scaling later, using an image-editing program, forces the computer to interpolate image information, producing a lower-quality enlargement.

ASCII is American Standard Code for Information Interchange, the basic digital code for alphanumeric symbols.



Figure 3.18 Slide and flatbed scanner.

device. For small production, these adapters to a flatbed scanner may suffice. For larger projects, more specialized scanners should be considered. Slide and film scanners are specifically calibrated to capture high spatial resolution, some at 4000 dpi. Sheet-fed scanners are built to automatically capture large print jobs and process 15 or more pages per minute. In selecting a scanner for multimedia development there are many considerations. Image or text source, quality of scan capture, ease of use, and cost all factor into choosing the right scanner.

Digital cameras are a popular input source for multimedia developers (Figure 3.19). These cameras eliminate the need to develop or scan a photo or slide. Camera images are immediately available to review and reshoot if necessary, and the quality of the digital image is as good as a scanned image. Digital capture is similar to the scanning process. When the camera shutter is opened to capture an image, light passes through the camera lens. The image is focused onto a CCD, which generates an analog signal. This analog signal is converted to digital form by an ADC and then sent to a digital signal processor (DSP) chip that adjusts the quality of the image and stores it in the camera's built-in memory or on a memory card (Figure 3.20). The memory card or stick has limited storage capacity. Images can be previewed on the card, and if not suitable, deleted to make space for additional images.



Figure 3.19 Digital cameras have a variety of features including size, storage capacity, megapixel, and optical zoom ratings.

Digital camera image quality, like scanning, is based on spatial resolution and color resolution. Most consumer-grade digital cameras use 24-bit color resolution. This is quite adequate for most multimedia development. Professional digital cameras often use 42- or 48-bit color resolution, allowing them to capture a wider range of data for manipulation by image-editing programs.

A digital camera's spatial resolution is measured in the number of pixels captured by the CCD. Early digital cameras were 1 megapixel. This means the maximum image resolution is 1200 horizontal by 800 vertical ppi ($1200 \times 800 = 960,000$, or close to 1 million pixels). The physical size of the image depends on where it is viewed. If this image is viewed on a monitor at 72 ppi, the image will appear quite large: 16 by 11 inches. If printed at 300 dpi, the image will be 4 inches wide by 2.6 inches high (Table 3.6). These camera images are fine for web pages or sending email attachments, but they do not capture sufficient data to produce high-quality, photolike printouts.

Newer digital cameras capture resolutions of 10 to 15 megapixels. Higher pixel ratings mean more realistic printed photographs. They also mean larger file sizes. If the camera is set to capture the highest-quality image, the total number of stored images is reduced. Most cameras have adjustments to lower the resolution and capture more images on the memory card or stick.

Images are transferred to a computer from the memory card through a USB adapter, a memory card reader, or wirelessly through Bluetooth or Wi-Fi. Image catalog programs such as iPhoto help to manage digital images on secondary storage. These files can then be edited using programs such as Photoshop or PaintShop Pro to enhance quality, adjust size, or add special effects. The digital camera has brought great efficiency to multimedia development. The costs of film, development, and time are reduced by digital source capture. It has also introduced a new level of creativity to the photo-editing process as developers take advantage of editing software to enhance and combine the digital photos.

Digital video (DV) cameras are another important input device for developers (Figure 3.21). Before DV cameras became effective and affordable, developers captured video in



Figure 3.20 Memory cards for digital cameras.

Dots vs. Pixels

Spatial resolutions are measured in *dpi* for print material and *ppi* for electronic display.

Table 3.6 Comparison of Selected Megapixel Ratings and Image Sizes

4 Megapixel	6 Megapixel	8 Megapixel	12 Megapixel
2700 h \times 1704 w = 4,600,800 total pixels	3008 h \times 2000 w = 6,016,000 total pixels	3266 h \times 2450 w = 8,001,700 total pixels	4290 h \times 2800 w = 12,012,000 total pixels
Viewed @ 72 ppi = 37.5" \times 23.6" image size	Viewed @ 72 ppi = 41.7" \times 27.7" image size	Viewed @ 72 ppi = 45.3" \times 34.0" image size	Viewed @ 72 ppi = 59.5" \times 38.8" image size
Printed @ 300 ppi = 9" \times 5.6" image size	Printed @ 300 ppi = 10.02" \times 6.67" image size	Printed @ 300 ppi = 10.88" \times 8.16" image size	Printed @ 300 ppi = 14.30" \times 9.34" image size



Figure 3.21 Digital video camera.

analog format. Analog video was played through a VCR to a video-capture board where the analog signal would be converted to digital format and stored on the hard drive. DV cameras eliminate that conversion process. Full motion capture is stored on a built-in hard drive, a tape, DVD, or memory card. DV cameras often have a FireWire interface to transfer a digital movie to other devices. Using applications such as Apple Final Cut Pro or Adobe Premiere, developers can edit and enhance the video in a wide variety of ways.

The performance of a DV camera is determined by several factors. The first is the method used to capture video data. Professional-quality video requires a 3-chip camera. These cameras have a separate CCD for each channel of red-green-blue (RGB) color. One chip captures the full range of reds, another greens, and the third blues. These three separate channels yield high-quality color. Less expensive consumer DV cameras use a single CCD and rely on sharpening algorithms to reproduce three channels of color. This tends to oversharpen the image and add artifacts to the moving images. While consumer DV cameras are an affordable means of capturing video footage and may suffice for some multimedia applications, a professional project will require the more expensive 3-chip cameras.

Lens and zoom quality are also important for high-quality capture. An inferior lens affects the camera's ability to reproduce color and capture sharp images. DV and still-image cameras feature **digital zoom**. This simulates the effect of a stronger telephoto lens by digitally enlarging and cropping an image. Digital zoom inserts additional pixels based on an analysis of the original image, in effect creating a "best guess" enlargement. Digital zoom is not a good substitute for high-quality optical zoom lenses that faithfully capture the details of the original image.

Most standard consumer DV cameras also have built-in automatic-exposure features, image stabilization (to compensate for the shaky hand), and preprogrammed modes that adjust video for backlit scenes, sports photography, snow, or spotlight scenes. A retractable liquid crystal display (LCD) screen displays the video and can be an alternative to using the eyepiece to frame a shot. Many consumer DV cameras also have a still-capture media card and can be used to take photographs, though usually at lower resolutions than a digital still camera.

Sound capture devices transform analog waveforms into digital files. Microphones are built into many computers and are useful for capturing voice commands and recording directly into applications such as PowerPoint. Built-in microphones, however, can introduce interference and are not suitable for high-quality capture. Developers often connect high-quality microphones directly to the computer's audio-capture port for better results. CD and tape players can also be plugged into a sound-capture board through the audio port. An ADC translates the analog sound wave into a digital file. Sound-editing software, such as Sound Forge or Audacity, can then be used to remove unnecessary segments, enhance sound quality, or add special effects.

Graphics tablets have a flat drawing surface for freehand image creation (Figure 3.22). The artist uses a stylus to draw on a pressure-sensitive surface. Software interprets the

stroke pressure to control density and color, reproducing the artist's drawing as a digital image. Tablets are also useful for tracing existing art. Many developers work with graphics tablets because of the intuitive drawing control they provide. The digital artwork they produce can then be directly manipulated with popular image-editing programs such as Photoshop or Corel Draw.

Multimedia Output Devices

Computer output devices present processed data in a useful form. Output devices include screen displays, audio speakers or headsets, and hard copy. The quality of output for display, sound, and print is dependent on the performance features of these devices.

Display Devices *Display devices* share their heritage with either cathode ray tube (CRT) technology used in analog televisions or liquid crystal displays (LCD) first used in calculators and watches. Both CRT and LCD technologies produce an image on a screen through a series of individual picture elements (pixels). As in scanners and digital cameras, the quality of a display image is largely determined by spatial resolution (the number of pixels) and color resolution (the bit depth of each pixel).

CRT monitors use **raster scanning** to generate a display. In this process an electronic signal from the video card controls an electron gun that scans the back of a screen with an electronic beam. The monitor's back surface is coated with a phosphor material that illuminates as electronic beams make contact. The electronic signal scans horizontal rows from the top to the bottom of the screen. The number of available pixels that can be illuminated determines the spatial resolution of the monitor. For example, a CRT with 1024×768 spatial resolution can display well over 700,000 pixels (Figure 3.23).

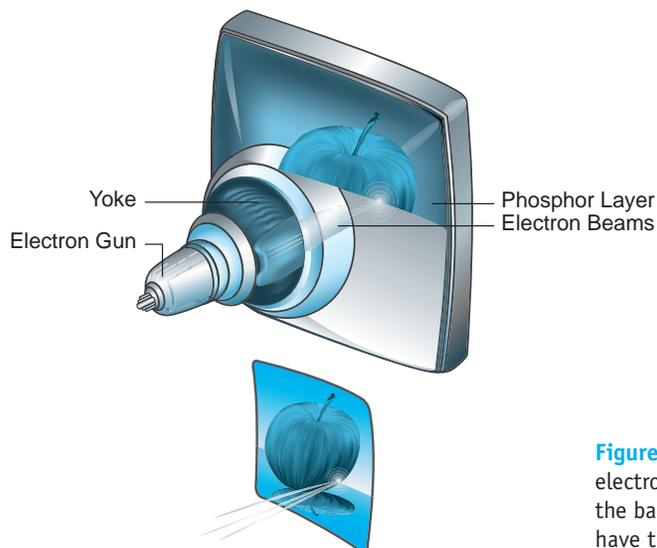

Figure 3.23 Raster scan CRT creates images through electron beams that illuminate a phosphor coating on the back of the monitor screen. RGB color monitors have three beams to illuminate red, green, and blue phosphors. See Color Plate 4.



Figure 3.22 Artists and designers use graphics tablets and a stylus pen to input drawings for further editing.

24- and 32-bit Color

24-bit color assigns 8 bits to each of three color channels—red, green, and blue. This produces 256 variations for each channel and 16.7 million colors for their combination ($256 \times 256 \times 256$). The extra 8 bits in 32-bit color does not produce more color options. Instead, this is an “alpha channel,” used to specify the transparency of each pixel.

Color resolution, or bit depth, is the second factor to influence display device performance. The number of bits per pixel determines the range of possible colors that are displayed. The video card controls bit depth. Video cards convert computer data to an electronic signal that illuminates the pixels. An 8-bit color monitor has a range of 256 color possibilities (2^8). This is sufficient for text and simple graphics, but a wider range of colors is needed for more sophisticated graphics and video. Current video cards generate 24- to 32-bit color, supporting 16.7 million colors.

CRT technology is now replaced with smaller, lighter-weight, fully digital displays that use a different technique to create pixels. An **LCD** screen is a sandwich of two plastic sheets with a liquid crystal material in the middle. Tiny transistors control rod-shaped molecules of liquid crystal. When voltage is applied to the transistor, the molecule is repositioned to let light shine through. Pixels display light as long as the voltage is applied. Laptops borrowed this technology and improved its resolution, color capability, and brightness to make LCDs suitable for computer display.

Laptop computers employ an **active matrix** screen that uses **thin film transistor (TFT)** technology. TFT displays assign a single transistor to each liquid crystal cell to control the color and light that compose a pixel. Each pixel on the LCD is a bundle of subpixels (red, green, and blue) that are combined to generate the array of colors.

Resolution and brightness impact the quality of LCD output. LCD screens have specific resolutions controlled by the size of the screen and the manufacturer. This fixed-pixel format is referred to as the *native resolution* of the LCD screen. A 15-inch LCD screen has a native resolution of 1024×768 pixels: there are exactly 1024 pixels in each horizontal line and 768 pixels in each vertical line for a total of 786,432 pixels. Altering the resolution to lower settings, 800×600 for example, reduces the output quality. Most LCDs use an expansion technique to fill the screen with the image at a lower resolution. Pixels are either doubled, producing a chunky effect, or added using interpolated colors, resulting in a blurred effect. Either way, the quality of the image is compromised. LCD screens should remain in their native resolution for best results. The brightness of light that shines through the screen is also significant in overall output quality. Brighter screens display richer graphics.

LED (light-emitting diode) displays have moved from large TV screens to mobile phones, tablets, laptops, and desktop screens. These displays use the same TFT display technology as the LCDs. A major distinction is in the manner of providing the light source to illuminate the pixels on the screen. LCD displays use a fluorescent lamp as the light source to project the colors through polarized liquid crystals. A single fluorescent tube, smaller than a pencil, provides a bright white light that is diffused across the back of the display without increasing the temperature of the panel. LED screens use a single row of light-emitting diodes to make a brighter backlight that significantly improves the quality of the monitor display. There are several advantages that come from altering the method of backlighting the liquid crystals. LED monitors offer more intense lighting and finer color resolution to deliver a more natural color experience. They use on average 40% less power than the LCD display, preserving battery life for mobile devices. Finally, the LED

display has a sharper image from any angle, unlike the LCD display that is best viewed directly in front of the monitor (Figure 3.24).

Sound Devices *Speaker systems* are essential components of modern computers. Most early microcomputers restricted sound output to warning sounds such as a loud beep when there was an error message. Macintosh computers raised the bar on sound output when the first Mac introduced itself to the world in 1984. A computer that could speak changed the prevailing belief that all computer information needed to be in visual form. Sound capability soon became a requirement for a multimedia computer.

Sound output devices are speakers or headsets. They are plugged into the soundboard where digital data is converted to analog sound waves. Soundboards can be a part of the system board or added to a computer's expansion slots. Soundboard circuitry performs four basic processes: it *converts* digital sound data into analog form using a digital-to-analog converter, or **DAC**; *records* sound in digital form using an ADC; *amplifies* the signal for delivery through speakers; and *creates* digital sounds using a synthesizer. A **synthesizer** is an output device that creates sounds electronically. Synthesizers may be built into the computer's soundboard or added later, usually as a card mounted in one of the system's expansion slots. The most common standard for creating digital music using a synthesizer is MIDI (Musical Instrument Digital Interface). MIDI specifies the format for musical commands, such as striking a piano key. The computer sends these commands to the synthesizer, which then creates the appropriate sound.

Sound quality depends on the range of digital signals the soundboard can process. These signals are measured as sample size and rate. *Sample size* is the resolution of the sound measured in bits per sample. Most soundboards support 16-bit sound, the current CD-quality resolution. *Sample rate* measures the frequency at which bits are recorded in digitizing a sound. Modern boards accommodate the 48 KHz sample rate found in professional audio and DVD systems. Soundboards control both sound input and output functions. Input functions are especially important for developers because they need to capture and create high-quality sounds. End users are concerned with output; they want high-quality sound for games, movies, and digital music.

Print Devices *Printers* remain an important multimedia peripheral device, despite the fact that multimedia applications are primarily designed for display. Storyboards, system plans, schematics, budgets, contracts, and proposals are just a few common documents that are frequently printed during multimedia production. End users print images and web pages, as well as the standard text documents associated with most computer applications.

There are two basic printing technologies: impact and nonimpact. *Impact printers* form images and text by striking paper. **Dot-matrix** printers use a series of pins that strike the paper through an inked ribbon. These printers are used for applications that



Figure 3.24 LED screens use a row of light-emitting diodes to backlight the display, resulting in better clarity, resolution, and color.

require multiform output or high-speed printing. They are easy to maintain and relatively inexpensive to operate. However, limited color and graphics capability, combined with high noise levels, make impact printers undesirable for most printing needs.

Nonimpact printers form printed output without physically contacting the page. These devices include inkjet, photo, and laser printers. **Inkjet printers** are used in many homes and businesses. They are affordable, quiet, and versatile: inkjets can print everything from labels and envelopes to photo-quality color images. An inkjet printer is a line printer. The print head moves across the page, one line at a time, spraying drops of ink. Different techniques are used to produce the ink spray, but the most common is the “bubble” jet method first implemented in 1977 by Cannon and later adopted by Hewlett-Packard (HP). As the ink cartridge moves across the paper, heat is applied to tiny resistors on the metal face of the print head. The surface of the ink boils, producing a vapor bubble. This bubble forces ink through a nozzle and onto the paper (Figure 3.25).

Inkjet output quality is determined by printer resolution and type of paper. Printer resolution is measured in dpi. The drop of ink is a dot. An image printed at 200 dots per inch will have more ink applied than one printed at 100 dots per inch. Inkjet printers can support optimized resolutions of 4800 dpi. Because the inks tend to blend together on the paper before they dry, inkjet printers can achieve higher-quality output with fewer dpi. Setting the print resolution to 200 dpi will deliver a reasonably good photograph and also reduce ink consumption.

Inkjet papers vary in surface texture. Glossy photo paper is used to transform digital images into printed photos, while matte finish paper can produce colorful reports.

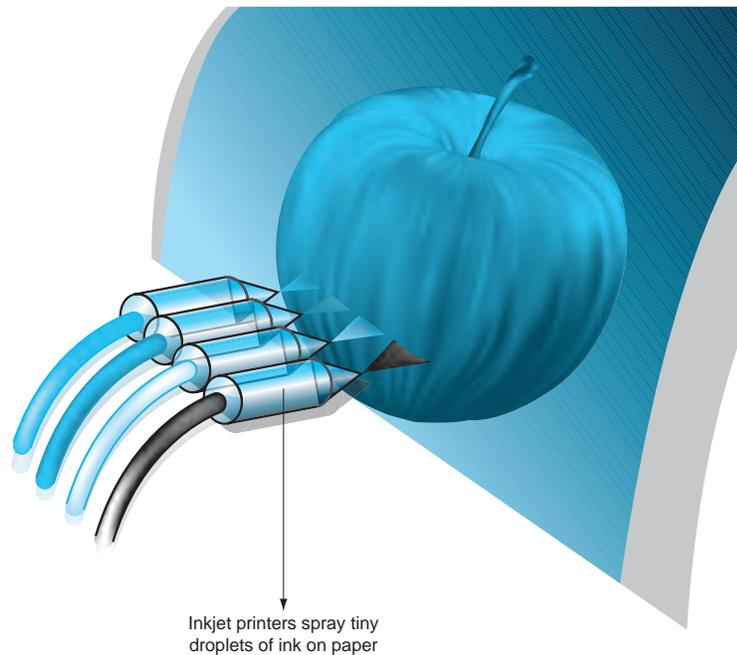

Figure 3.25 Inkjet printers spray dots of colored ink to form an image. See Color Plate 5.

Papers with linen or cotton fibers and textured papers will bleed where ink is applied. For best results, use paper specifically designed for inkjet printers.

Printer speed is measured in pages per minute (ppm). Inkjet printers average 20 ppm. Color printing is much slower than black and white output. A typical black and white speed is 18 ppm whereas color output slows to 12 ppm.

While most inkjet printers are very affordable, the cost of consumables can be high. Print cartridges are expensive to replace (Figure 3.26). Expect to replace color cartridges frequently if the output is full-size color photos. Specialty papers for high-gloss photos are also expensive. Paper and ink costs should be factored into the decision to use inkjet printing for multimedia production.

A **photo printer** is a color printer specifically designed to produce photos (Figure 3.27). The best photo printers can deliver photo lab-quality output. Many consumer photo printers are based on inkjet technology. These printers use a media card from a digital camera and have a push-button panel to set the size, quality, and number of copies. Images do not have to be transferred to a computer before they are printed. This increases the ease and speed of sharing digital pictures. Some inkjet printers are configured as both a standard and photo printer by adding a media card slot and panel controls to manage the photo printing. More expensive photo printers use dye sublimation technology for output. **Dye sublimation** uses heat to transfer colored dye to specially coated papers. These printers are found in professional settings such as photography studios and digital imaging labs.

Laser printers use a copier-like technology to fuse text and image to the paper. They are called *page printers* because the entire page is transferred to the printer's electronic storage before it is formed on paper.

Laser printing begins with document transfer to the printer's electronic storage. A laser beam then scans an **optical photoconductor (OPC)** drum, placing a negative electrical charge where text and images should appear. Toner, a form of powdered ink, is attracted to these charged areas. When paper moves through the printer, it passes under the OPC drum, which deposits the toner. Other rollers add heat and pressure to fuse print material on the page. Because lasers print an entire page at once, they are faster than inkjet printers.

Laser printers have resolutions of 600 to 2400 dpi. Common print speeds range from 20 to 45 ppm. Laser printers are very popular in offices with large black and white print jobs where quality and speed are imperative. For years, inkjet printers held the advantage of color over a standard laser printer. Color laser technology is now delivering high-quality color output at reasonable costs.



Figure 3.26 Inkjet cartridges.



Figure 3.27 Photo printers can crop, enlarge, and enhance the image before printing on special photo paper.

Color laser printers add cyan, magenta, and yellow toners to traditional black. Applying additional toners slows printing speeds. The laser scans each color separately to the OPC drum, making a separate pass of the drum to collect each color for the entire page. Early printers moved the paper past the drum each time to collect a particular color, but the constant movement of paper back and forth through the printer rollers often misaligned the color output. Now one-pass color lasers simply move the drum four times around to collect toner for each color and then pass the paper once to transfer the final colored image. Color laser printers are significantly slower than standard black and white lasers because there is extra processing for each color.

Color laser printers require large electronic storage capacity. A full-page, 600-dpi color image may require over 16 MB of printer storage. If the printer cannot form the entire page in memory, it will only print the portion it can store. In some cases, insufficient memory produces an error message and the page is not printed at all. Color laser printers should have from 128 MB to 512 MB of primary storage.

Considerations for Selecting a Printer

- Resolution (measured in dpi)
- Speeds (measured in ppm)
- Cost of the printer
- Cost of consumables (paper, inks, toner)
- Paper-handling features (duplexers, envelopes, labels, legal, continuous paper forms)
- Built-in memory capacity (more is always better)
- Computer and network interface (USB, parallel, Ethernet capable)
- Maintenance requirements (service contracts, cleaning requirements, operating environment)

Laser printers are desirable output devices because they have high-quality and high-speed output. However, these printers are expensive to operate. Operational expenses include toner cartridges, service contracts, and paper. Laser printers also require special environmental conditions. Excessively dry or damp atmospheres will affect printer operation. Many multimedia development offices share laser printers through network connections, reducing the cost to individual users. Most laser printers have built-in network cards for Ethernet LANs (local area networks).

In addition to standard printers, there are other print devices for specialized applications. Plotters, portable printers, and label printers are just a few. A hybrid device that combines printer, scanning, fax, and copier technology in one unit is called a **multifunction printer**. This single unit saves desk space and eliminates the need for purchasing separate output devices. All printing devices utilize either the basic impact or nonimpact methods. When selecting printers for multimedia development, consider the purpose of the output and the media to print. If documents are text-based reports for staff members, high-quality, expensive printers may not be necessary. If the media is detailed images for production design, then a printer with high color resolution is important.

3.4 Networks

Multimedia projects may require input from many individuals working independently on their personal computers. The integration of this work requires a network of computers. A **network** is a collection of computers connected through a communication link to share hardware, data, and applications. Networks also allow individual processors in each computer to work simultaneously on a single task. Complex rendering projects for animation sequences are frequently done with an array of networked computer proces-

sors called a “render farm.” Networks are the backbone that ties together the work of individual developers and the resources of their personal computers.

Computer networks are categorized as *WAN* (wide area network) or *LAN* (local area network). The **WAN** connects computers over a wide geographic region using the communication lines of an outside service provider such as a telephone or cable company. A developer can transfer digital files via email attachments or use *file transfer protocols* (FTP) to add digital files to a remote network server. In both cases, the computer connects to other systems through external communication links.

The **Internet** is a special form of WAN. It is a network of networks that uses Transmission Control Protocol and Internet Protocol (**TCP/IP**) to send data from one computing device to another. **Protocols**, or rules for transmitting data, control the transfer and addressing of data between each host computer. The Internet started in 1969 as a government research project with four computer systems interconnected to share system resources. Twenty years later, the Internet exploded with possibilities when Tim Berners-Lee developed the HTTP (hypertext transfer protocol) protocols for the **World Wide Web (WWW)**.

The Web introduced interactive multimedia to the Internet. Web pages, written in *HTML* (Hypertext Markup Language), display multimedia through a browser such as Internet Explorer or Safari. **Hyperlinks** connect resources from one web page to another location. Hyperlinks are defined with a **uniform resource locator (URL)** that identifies the path to an Internet resource such as an image, web page, or video file.

The efficiencies of the Web are in its *client/server* model for distributing data. **Server** computers store and send data to a client computer. **Client** computers have software to open and process data files. Once data is downloaded from the server, applications on the client computer, such as browsers and plug-ins, display or play data content. Client computers process data locally, which is more efficient than processing it on a server computer shared by thousands of users.

Special data file formats are necessary to ensure data is compatible on any client system. For example, image files include .jpg, .gif, or .png format and text files use .html or .pdf format. Incompatibilities between computer platforms and data file formats are slowly disappearing through the network connections and protocols of the World Wide Web.

<http://www.jblearning.com/about/overview/>
This URL identifies the http protocol, the host computer (jblearning), the domain (.com), and the path to a specific document resource on that host (/about/overview/).

A **LAN** is a series of computers connected within an organization. Many homes now have a LAN to share printers and access to the Internet. Multimedia developers connect computers to distribute files, access applications from a local server, or share hardware devices. Computers on a LAN can be connected using twisted pair cable that resembles a phone line, although wireless connectivity is increasingly common.

Ethernet is a common set of protocols to control the flow of data on a LAN. Ethernet defines how files are transferred, the speed of transfer, and the cables used to connect the computers. Many LANs are using wireless connections as computers become more mobile and users desire flexible network access. A wireless network requires an **access point** (AP) that broadcasts a radio signal within a cell area. The AP often contains a fire-wall to prevent unauthorized wireless network access. The AP is connected to a larger network system through a cable modem or **router** (a switch to control data flow on a

network). Computers need a wireless card or built-in wireless capability to send and receive data via radio waves.

Wi-Fi and Bluetooth are two popular wireless LAN standards. The **Wi-Fi (wireless fidelity)**, or 802.11b standard, transmits on 2.4 GHz radio frequencies. Transmission rate is 11 Mbps up to 300 feet away from the AP. Distance, interference, and number of users can adversely affect the transmission rate. Frequent upgrades to this standard introduce higher bandwidth and increased reliability of data transfer within the 2.4 GHz frequency range. The 802.11g provides bandwidth up to 54 Mbps and 802.11n introduces newer transmission techniques to achieve up to 100 Mbps. The **Bluetooth** protocol was developed in 1994 to communicate between devices within 30 feet at 1 Mbps speeds. Bluetooth is designed to transfer data between nearby computers and PDAs, or to communicate with a nearby printer or other peripheral device.

Networks have increased the power of individual computers and expanded the efficiency of computer users. Networks are also instrumental in fulfilling the visions of Bush and Nelson to build “trails” from one data point to another.

3.5 Summary

Computers are manufactured in many sizes and platforms. Mainframe and supercomputers are used in organizations with high volumes of data and complex processing requirements. Personal computers use microprocessors to bring computing power to the desktop of both multimedia developers and end users. Personal computers are defined by their platform, the combination of hardware and operating system they use. Multimedia developers must consider the development platform that meets their project requirements, as well as the delivery platform, the computer system available to potential users.

All computer hardware systems share the basic functions of input, processing, storage, output, and transmission of data. The system unit, consisting of the CPU, primary memory, expansion ports, and the circuitry that connects them, provides the foundation for processing digital instructions and data. Peripheral devices support processing through input and output interfaces on the system board. Hard drives, CD and DVD drives, and solid-state media are common peripheral devices that support the main processing activity by storing software and data for later processing. Large capacities of permanent, portable storage are necessary to deliver the applications expected of today's multimedia computers. Networks unite computer hardware making it possible to share and distribute media within local organizations or over wide geographic areas.

The evolution of multimedia hardware is far from complete. New devices appear daily. The marvel of the digital computer is its scalability and adaptability. Computer microelectronics move ever-larger volumes of data at ever-increasing speeds. Processors transform those bits into wondrous images and sounds. But even the most advanced hardware is simply a collection of components awaiting instructions and data from a user. Software, the subject of the next chapter, transforms electronic computers into useful tools to create and manage an increasingly interconnected world of digital multimedia.

Key Terms

Access point
Access time
Active matrix
ADC
Address bus
Arithmetic logic unit (ALU)
ASCII
Bit depth
Blu-ray
Bluetooth
Bus
Cache
Constant angular velocity (CAV)
CCD
CD-DA
CD-R
CD-ROM
CD-RW
Client
Clock speed
Cloud storage
Color resolution
Computer platform
Computer system
Constant linear velocity (CLV)
Control unit
CPU
Cross-platform compatibility
CRT
DAC
Data bus
Digital zoom
Dot-matrix printer
DVD
Dye sublimation
Ethernet
FireWire
Flash drive
Flash memory
Frame
Hard drive
Hardware interface
Hyperlinks
Inkjet printer
Instruction set
Interface ports
Internet
LAN
Land
Laser
Laser printer
LCD
LED
Machine cycle
Magnetic storage
Mainframe computer
Memory card
Microcode
Microcomputer
Microprocessor
Mobile computing platform
Multicore
Multifunction printer
Multiprocessing
Multitasking
Nanotechnology
Network
Optical character recognition (OCR)
Optical photoconductor (OPC)
Optical storage
Parallel data transmission
Parallel processing
Peripheral devices
Personal computer (PC)
Photo printer
Pipelining
Pit
Pixel
Primary memory
Protocols
Random access
Random access memory (RAM)
Raster scan
Read-only memory (ROM)
Registers
RISC
Router
Scanner

Secondary storage	TCP/IP
Sector	Thin film transistor (TFT)
Serial data transmission	Thunderbolt
Server	Track
Session	Transfer rate
Solid-state storage	Uniform resource locator (URL)
Spatial resolution	Universal Serial Bus (USB)
Storage capacity	USB 3.0
Supercomputer	WAN
Synthesizer	Wi-Fi
System board	Word size
System bus	World Wide Web (WWW)
System unit	

Resources

Taylor, Jim. 2005. DVD Frequently Asked Questions (and Answers). *DVD Demystified*. <http://www.dvddemystified.com/>

Review Questions

1. What are the differences between a supercomputer, mainframe, and microcomputer?
2. What are the two main components of a computer system?
3. Why should a multimedia developer be concerned about cross-platform compatibility?
4. What are the two main categories of computer hardware? Explain the function of each.
5. Why is the system board an essential component of the system unit?
6. What are the three main sets of transistors on a microprocessor chip? Identify the main purpose of each set.
7. How do clock speed and word size determine the performance of a CPU?
8. What is the advantage of a 64-bit address bus over a 32-bit bus?
9. What are the differences between and uses of RAM and ROM?
10. How does cache memory improve the overall performance of a processor?
11. What are the similarities and differences between USB and IEEE 1394 interfaces?
12. Why is the transfer speed of the hardware interface important to a multimedia user and developer?
13. What are the magnetic storage options for portable media?
14. How do pits and lands on an optical disc store digital data?
15. What is one advantage and one disadvantage of the CLV method of data storage?
16. Why does the *V* in DVD currently stand for *versatile*?
17. Why can DVDs store more data than CDs?
18. What are three input devices that would be useful for a graphics artist?

19. What are the three computer display technologies? Identify a major distinction of each.
20. What is an advantage and disadvantage of each of the following printer categories: inkjet printer, laser printer, photo printer, and color laser printer?
21. What is the distinction between a WAN and a LAN?
22. What features did the WWW introduce to the Internet?
23. What are the essential similarities and differences between Wi-Fi and Bluetooth?
24. Why is the Internet a special form of WAN?
25. Why is the client/server arrangement an efficient use of the server's processor and the network's bandwidth capacity?

Discussion Questions

1. Recommend four essential system unit performance features a video developer should consider when purchasing a computer to import, edit, and store digital video.
2. Identify the five main uses of secondary storage and recommend a storage medium for each one to manage 900 MB of digital sound.
3. What are the three major categories of secondary storage devices? List the main advantages and disadvantages of each.
4. Do you think CD-RW/DVD drives will soon replace magnetic external storage devices? Explain your position.
5. As a video editor on a multimedia production team, what type of secondary storage would you use for composing and editing the digital video? Explain your choice.
6. Many organizations are storing all their vital data on cloud storage services. Do you think this is a good idea? What are the most important issues to consider? Support your answer with web research on these issues.
7. Locate a recent ad for a flatbed scanner and describe the performance features of that scanner.
8. Locate a recent ad for a digital camera and describe the performance features of that camera.
9. Will solid-state storage soon replace magnetic storage? Explain your position.
10. Research how render farms are used to develop digital animation sequences and report your findings.
11. Research two cloud storage providers and compare the features of each. Identify specific provisions each makes for the security and privacy of your data.
12. Review the vision of Vannevar Bush and Ted Nelson and determine if today's networks and search engines are fulfilling their vision. Explain why they are or are not.

